

MARINE  
EQUIPMENT  
GUIDE | 08  
09



# Lewmar Steering

Lewmar steering systems are designed for style and convenience. Each wheel, system and accessory was created to help improve the time you spend out on the water and make boating an easier, more enjoyable experience.

## Steering you in the right direction.

Lewmar's steering systems and products have been world leaders for over 40 years, constantly evolving to meet the performance and aesthetic needs of both cruisers and elite racers.

Each product is thoroughly tested in the most adverse conditions possible and then finished with care to suit every type of yacht.



## Wheel Selection Guide

cm	66	81	97	112	127	142	157	173	188
in	26	32	38	44	50	56	62	68	74
<b>Folding Wheel</b>									
<b>Commodore™ Flat</b>									
<b>Commodore™ Dished</b>									
<b>Mini Maxi™</b>									
<b>Carbon</b>									
<b>Fastnet</b>									

### Multi-Tooth Wheel Disengagement Units

This is a quick, safe and efficient way to disengage the steering wheel while still allowing the system to operate. This is particularly useful when using a dual-wheel system or operating the steering by Autopilot. The unit incorporates precision multi-tooth gears to ensure zero backlash or play.



*Note: This product cannot be retrofitted to an existing wheel and must be requested when ordering a new wheel. This multi-tooth disengagement unit can be added to any style of newly built Lewmar wheel. For prices and part numbers of wheels incorporating this product please speak to a Lewmar representative or your local distributor.*

### The Lewmar Steering Wheel Shaft

All Lewmar wheels listed in this catalogue have the 25mm/1" taper shaft. Angle of taper ensures the wheel is easily removable. Larger wheels (1.6m and up) can also be supplied with the 30mm/1 3/16" taper shaft. The folding wheel dual-hub also fits a 25mm/1" parallel shaft.

Lewmar uses the industry standard 25mm/1" tapered and keyed shaft to ensure positive fit of the steering wheel. The 30mm/1 3/16" taper shaft is only used in custom super yacht systems.

#### 25mm taper shaft

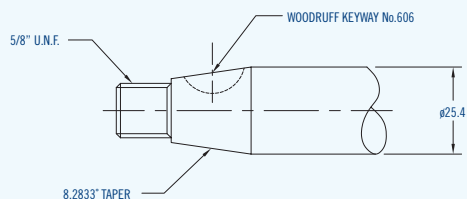

#### 30mm taper shaft

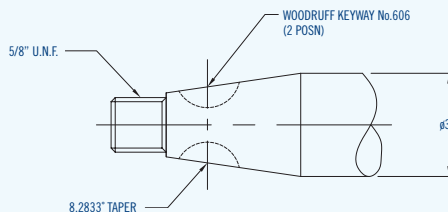

### Brake Spinner

A brake spinner is used to lock the wheel and rudder when in port or at anchor. Lewmar uses a powerful and progressive through shaft friction brake. It is specific to the type of wheel used. For more information and part numbers, refer to the wheel section on pages 184 to 187.



## Cockpit living is easy with the space-saving Lewmar Folding Wheel.

Lewmar's innovative and patented Folding Wheel is now available at your local retailer. Its unique, fast-action folding system is a concept in space-saving technology. Conventional wheels significantly restrict your cockpit space, but the Lewmar Folding Wheel breaks down that barrier. Ideal for a wide range of yachts, including those with twin-wheeled layout. The Folding Wheel has a two-turn, buttress-threaded, split-spoke design, and a unique hinging system with fast-action handgrip release. This allows you to easily fold and unfold the wheel, using a simple twist of the composite handgrip. At a fraction of the cost of custom versions, the Folding Wheel is appealing to both production boat builders and owners looking to improve their deck layouts.



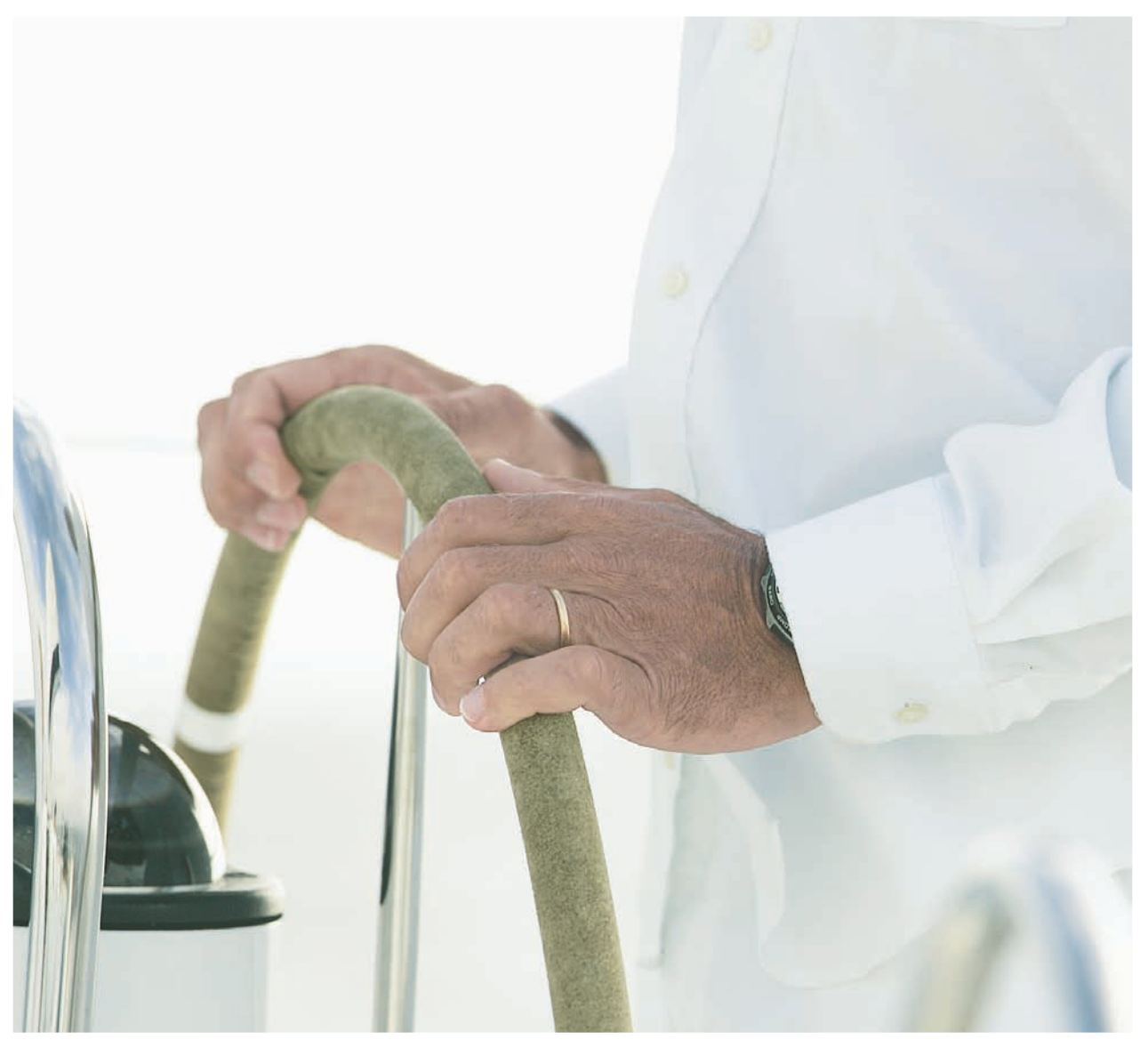

## 6-spoke Folding Wheel with Hide Cover

Part No.	Description	Size		Fit Shaft
		cm	in	
89700375	Folding Wheel 6-spoke Hide Cover	81	32	1" taper
89700376	Folding Wheel 6-spoke Hide Cover	91	36	1" taper
89700377	Folding Wheel 6-spoke Hide Cover	102	40	1" taper
89700520	Folding Wheel 6-spoke Hide Cover	107	42	1" taper
89700406	Folding Wheel 6-spoke Hide Cover Dual Hub	81	32	1" taper & 1" parallel
89700407	Folding Wheel 6-spoke Hide Cover Dual Hub	91	36	1" taper & 1" parallel
89700408	Folding Wheel 6-spoke Hide Cover Dual Hub	102	40	1" taper & 1" parallel
89700521	Folding Wheel 6-spoke Hide Cover Dual Hub	107	42	1" taper & 1" parallel

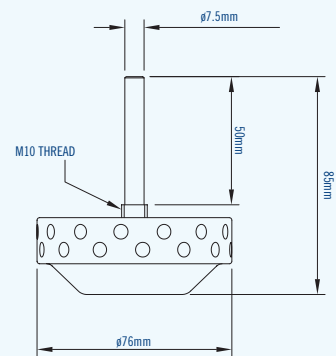

**8910 0143**  
Brake Spinner

# The Commodore™ Wheel

Durable and elegantly styled, the Commodore™ is a standard choice for yachtsmen the world over.

Choose from sizes ranging in diameter from 66cm (26") to 122cm (48").

Part No.	With	With Hide	Description	Size	
	Hide Cover	Cover & Spats		cm	in
89700253	89700264	89700275	5-spoke flat	66	26
89700254	89700265	89700276	5-spoke flat	71	28
89700255	89700266	89700277	5-spoke flat	76	30
89700256	89700267	89700278	5-spoke flat	81	32
89700257	89700268	89700279	5-spoke flat	91	36
89700286	89700297	89700308	5-spoke dished	66	26
89700287	89700298	89700309	5-spoke dished	71	28
89700288	89700299	89700310	5-spoke dished	76	30
89700289	89700300	89700311	5-spoke dished	81	32
89700290	89700301	89700312	5-spoke dished	91	36
89700291	89700302	89700313	5-spoke dished	102	40
89700011	89700024	89700037	8-spoke flat	107	42
89700431	89700432	89700646	8-spoke flat	112	44
89700012	89700025	89700038	8-spoke flat	122	48
89700050	89700063	89700076	8-spoke dished	107	42
89700051	89700064	89700077	8-spoke dished	122	48

Note: Contact Lewmar for smaller wheel sizes if required.

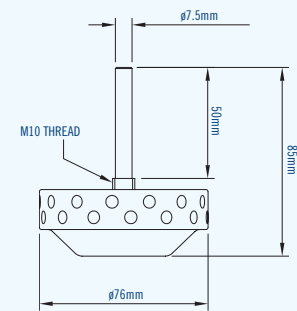

**89100143**  
Brake Spinner

# The Mini Maxi™ Wheel

The Mini Maxi™ wheel is designed for use where a larger wheel is required or for exceptional rigidity. The Mini Maxi™ wheel is available up to 1.5m/60" in diameter.

Part No.	With	With Hide	Description	Size	
	Hide Cover	Cover & Spats		cm	in
89700078	89700085	89700092	Mini Maxi™ 10-spoke	91	36
89700079	89700086	89700093	Mini Maxi™ 10-spoke	102	40
89700080	89700087	89700094	Mini Maxi™ 10-spoke	107	42
89700081	89700088	89700095	Mini Maxi™ 10-spoke	122	48
89700082	89700089	89700096	Mini Maxi™ 10-spoke	132	52
89700083	89700090	89700097	Mini Maxi™ 10-spoke	137	54
89700084	89700091	89700098	Mini Maxi™ 10-spoke	152	60

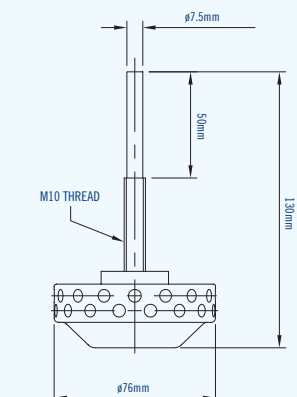

**89100144**  
Brake Spinner



# Carbon Wheel

The Y-Spoke carbon wheel combines the ultimate in weight saving with sleek and slender styling. Ideal for Grand Prix Race Yachts or as a solution to increasing demand for race technology on cruising yachts. These wheels are built and supplied to order in a variety of sizes ranging from under 1m/39" to 1.8m/71".



Part No.	Description	Size		Weight	
		m	in	kg	lb
89700411	Carbon Y-Spoke/painted finish	0.9	36	1.9	4.2
89700412	Carbon Y-Spoke/painted finish	1	39	2	4.4
89700410	Carbon Y-Spoke/painted finish	1.1	43	2.1	4.6
89700413	Carbon Y-Spoke/painted finish	1.2	47	2.2	4.8
89700414	Carbon Y-Spoke/painted finish	1.3	51	2.5	5.5
89700415	Carbon Y-Spoke/painted finish	1.4	55	2.8	6
89700383	Carbon Y-Spoke/painted finish	1.5	59	3	6.6
89700416	Carbon Y-Spoke/painted finish	1.6	62	3.1	7
89700451	Carbon Y-Spoke/painted finish	1.7	67	3.3	7.3
89700417	Carbon Y-Spoke/painted finish	1.8	71	3.5	7.7

Will fit **89800108**  
Carbon wheel st/st brake spinner  
or  
**89800098** Carbon look brake spinner



# Fastnet Wheel

The Fastnet wheel is made from Alloy 6082 and is lightweight and stylish. These wheels are built to order and supplied powder coat painted black with black leather to the wheel rim as standard. We can offer white painted wheels and alternative leather color options to cover the wheel rims upon request. The Fastnet wheel range starts at 122cm/48" with incremental sizes up to 175cm/69".



Part No.	Description	Size	
		cm	in
89700601	Fastnet Alloy Hide Fitted, Black paint and black leather	122	48
89700602	Fastnet Alloy Hide Fitted, Black paint and black leather	127	50
89700603	Fastnet Alloy Hide Fitted, Black paint and black leather	132	52
89700604	Fastnet Alloy Hide Fitted, Black paint and black leather	137	54
89700605	Fastnet Alloy Hide Fitted, Black paint and black leather	140	55
89700571	Fastnet Alloy Hide Fitted, Black paint and black leather	147	58
89700591	Fastnet Alloy Hide Fitted, Black paint and black leather	150	59
89700581	Fastnet Alloy Hide Fitted, Black paint and black leather	160	63
89700607	Fastnet Alloy Hide Fitted, Black paint and black leather	175	69

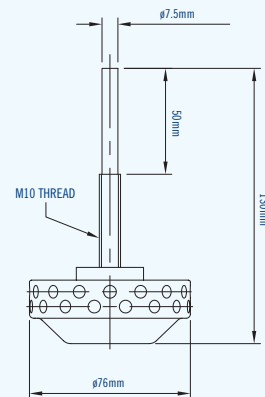

**89100144**  
Brake Spinner

# Wheel Accessories (continued)

## Quick Release Bi-square Wheel Nuts

The quick release wheel nut – with a standard winch handle bi-square. As you always have a winch handle on hand, this is a quick and simple way to remove your wheel. The quick release wheel nut is available in 316 grade stainless steel, to mirror polish finish.



Part Number	Wheel Type
89700161	Commodore™ Wheel / Folding Wheel
89700162	Mini Maxi™/Carbon/Fastnet

## Rail Mount Wheel Holder

The Rail Mount wheel holder can be used on most boat rails to store the wheel when not in use, thus providing a clear area in the cockpit.

- Manufactured in 316 investment cast Stainless Steel
- Designed to suit 25mm/1" taper or parallel steering wheel shaft
- Will fit 25.4mm/1", 28.6mm/1 1/8" & 32mm/1 1/4" diameter rails



89400327  
Rail Mount  
Wheel Holder

## Luxury Hide Covers

Hide covers add a touch of luxury to a stainless steel or aluminum wheel and increase the comfort and pleasure of helming. Hide covers can either be supplied fitted to the wheel or as an easy-to-fit kit for new wheels or to replace old covers. The following table shows kits for the Commodore wheels.

Lewmar can also provide hide cover kits for Mini Maxi wheels.

## Luxury Hide Cover Kits Commodore Wheels

Part No.	Hide Cover Kit	Size	
		cm	in
89700344	Hide Cover 5-spoke	66	26
89700345	Hide Cover 5-spoke	76	30
89700346	Hide Cover 5-spoke	81	32
89700347	Hide Cover 5-spoke	91	36
89700348	Hide Cover 5-spoke	101	40
89700125	Hide Cover 8-spoke	106	42
89700126	Hide Cover 8-spoke	122	48
89700354	Hide Cover & Spats 5-spoke	66	26
89700355	Hide Cover & Spats 5-spoke	76	30
89700356	Hide Cover & Spats 5-spoke	81	32
89700357	Hide Cover & Spats 5-spoke	91	36
89700358	Hide Cover & Spats 5-spoke	101	40
89700137	Hide Cover & Spats 8-spoke	106	42
89700138	Hide Cover & Spats 8-spoke	122	48



*Note: Above leather kits are supplied in Tan leather; other colors are available upon request. Please speak to your local distributor for further details, part numbers and pricing. Lewmar also offers leather cover kits to suit Mini Maxi and Fastnet wheels upon request as well as a re-covering service for existing older wheels.*





# Pedestal Selection Guide

## Specification Guidelines

Pedestals	Aft Cockpit					Center Cockpit		Tiller-Wheel Conversions	
	For Boats Up to 60ft Constellation™ (Open Wire)	For Boats Up to 60ft Cobra™ Cruising	For Boats Up to 60ft Cobra™ Ocean	For Boats Up to 60ft Cobra™ Racing	For Boats Up to 200ft Mamba™	For Boats Up to 80ft Constellation™ (Conduit)	For Boats Up to 80ft Mamba™	Constellation™ (Open Wire)	Cobra™ Cruising
Enguard	•	•		•	•	•	•	•	•
Integra	•	•		•	•	•	•	•	•
Reliant	•	•			•	•	•	•	•
Royale	•	•	•		•	•	•		
Maximum Wheel Size	2m/78"	1.2m/48"	1.2m/48"	2m/78"	2m/78"	2m/78"	2m/78"	2m/78"	1.2m/48"

- Lewmar pedestals are manufactured from modern composites, which guard against electrolytic action and the corrosive nature of salt water.
- All standard Lewmar pedestals measure 710mm/28" from the base to center of steering shaft. Custom pedestal heights are available upon request.
- All Lewmar pedestals (except the Athena range) are available in Constellation, Cobra and Mamba steering systems.
- Guardrails are not included (except Athena and Ranger models). For guardrail options refer to p.194-195.
- Lewmar offers a comprehensive range of pedestal accessories and options from guardrails and engine control to compasses, cockpit tables and instrument pods.



## Enguard Pedestal

The Enguard pedestal incorporates an integral guardrail pedestal base, which minimizes the footprint area the pedestal takes up on the deck.

The Enguard pedestal can be found fitted to many production boats around the world such as Hunter, Hanse and Northshore.

### Enguard Pedestal Dimensions

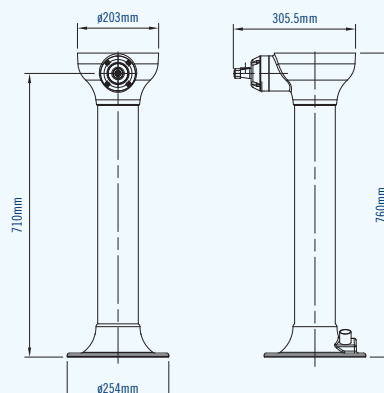

### Features

- Integrated guardrail base providing compact and rapid installation
- Wide range of accessories available

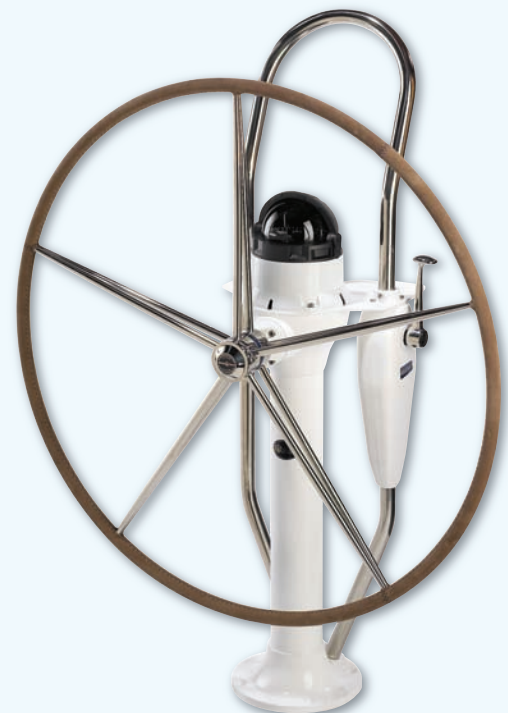

A typical installation with accessories

# Integra Pedestal

The Integra pedestal is the latest in Lewmar's range of integrated pedestal steering systems. The Integra offers quick and easy above-deck access to fit Lewmar's patented autopilot drive motor. The Integra pedestal can be found fitted to many production boats around the world such as Hunter, Delphia, Northshore and Linjett.

## Integra Pedestal Dimensions

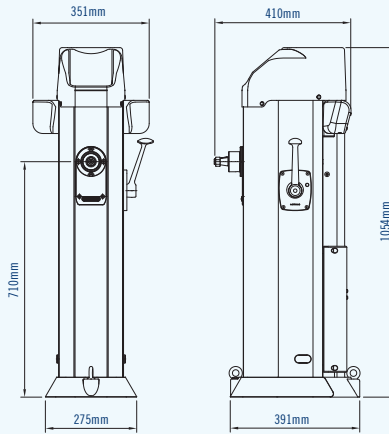

Part No	Description
89900302	Constellation Integra - Sprocket: 5/8P 11T
89900303	Constellation Integra - Sprocket: 5/8P 13T
89900305	Constellation Integra - Sprocket: 3/4P 11T
89900299	Cobra Cruising Integra
89900300	Cobra Racing Integra
89900306	Mamba Integra BH10

## Features

- Compass mounting platform and integrated housing
- Ability to mount one single instrument to the uPVC top molding
- Pre-installed single lever engine control
- All Integra Cobra pedestals enable you to install an integrated autopilot drive
- Removable access door for quick and simple autopilot installation
- Harness bolts supplied as standard on the forward and aft sides of the pedestal deck flange
- Pedestal pre-drilled for cockpit table mounting
- Pedestal stop ring included



A typical installation with accessories

# Reliant Pedestal

The Reliant pedestal is the first step in the 'Console' range of Lewmar pedestals. The Reliant utilizes the 'Premier Tube' platform, shared with the Royale and Ranger Pedestals. The Reliant pedestal can be found fitted to many production boats around the world such as Oyster, and Moody.

## Reliant Pedestal Dimensions

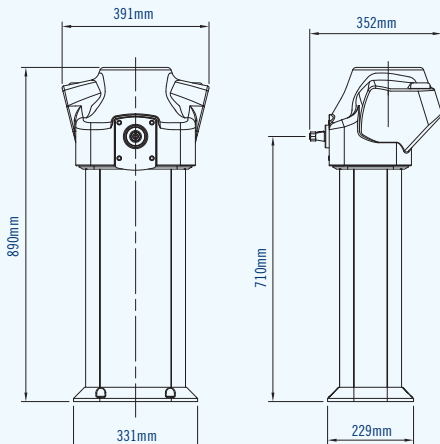

## Features

- Mounting areas for a single engine control on port or starboard
- Wide range of accessories available

Part No	Description
89900010	Constellation Reliant - Sprocket: 5/8P 11T
89900011	Constellation Reliant - Sprocket: 5/8P 13T
89900012	Constellation Reliant - Sprocket: 3/4P 11T
89900033	Cobra Cruising Reliant
89900043	Cobra Racing Reliant
89900050	Mamba Reliant BH10



A typical installation with accessories

# Royale Pedestal

The Royale is an evolution of the console style pedestal range.

The Royale head provides maximum flexibility for instrument mounting, and the Royale pedestal can be found fitted to many production boats around the world such as Harmony, Tartan and Najad.

## Royale Pedestal Dimensions

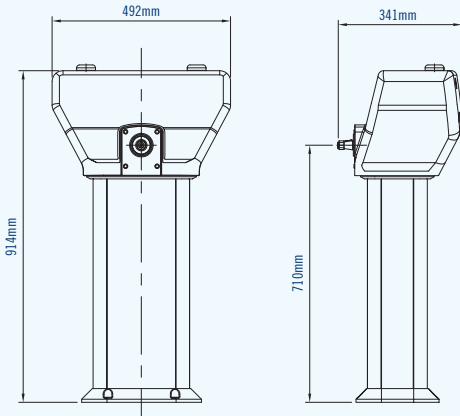

### Features

- Mounting areas for a single engine control on port or starboard
- Accepts 4 industry standard 110mm/4 1/4" yachting instruments
- Flush mount compass platform



A typical installation with accessories

Part No	Description
89900014	Constellation Royale - Sprocket: 5/8P 11T
89900015	Constellation Royale - Sprocket: 5/8P 13T
89900016	Constellation Royale - Sprocket: 3/4P 11T
89900034	Cobra Cruising Royale
89900037	Cobra Ocean Royale
89900052	Mamba Royale BH10

# Athena Pedestal

The Athena has been designed for the larger yacht to provide a greater area for mounting instrumentation and controls. It can be found fitted to custom and production boats around the world such as Oyster.

## Athena Pedestal Dimensions

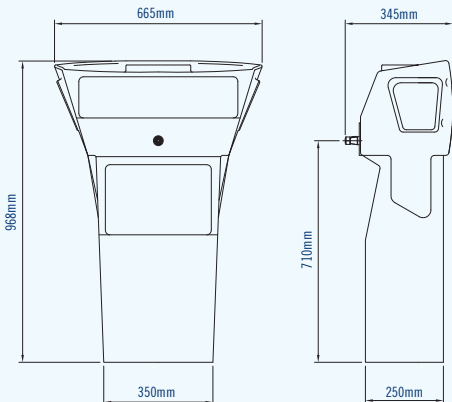

### Features

- Available in Constellation and Mamba steering systems
- Molded in glass fiber with reinforced stainless steel mounting plate and bearing supports
- Mounting areas for a single engine control on port or starboard
- Flush mount compass platform
- Large area for multiple control instruments
- Guardrail included



A typical installation with accessories

Part No	Description
89900022	Constellation Athena - Sprocket: 5/8P 11T
89900023	Constellation Athena - Sprocket: 5/8P 13T
89900024	Constellation Athena - Sprocket: 3/4P 11T
89900056	Mamba Athena BH10
89900057	Mamba Athena BH130



# Ranger Pedestal

Designed in response to the market demand for more pedestal-mounted instruments, including Radar and chart plotter.

## Ranger Pedestal Dimensions

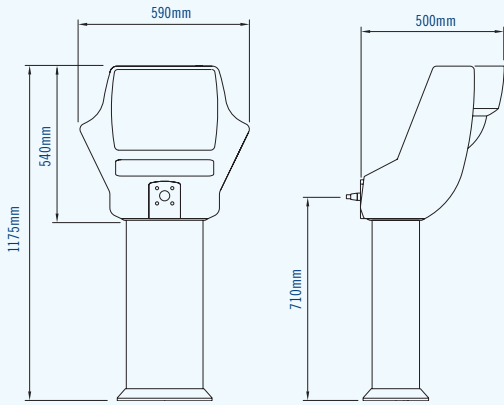

A typical installation with accessories

## Features

- GRP head manufactured to the highest quality finish
- Designed to mount 3 industry standard instruments, plus radar or chart plotter
- Mounting areas for a single engine control on port or starboard
- Flush mount compass platform
- Guardrail included

Part No	Description
89900198	Constellation Ranger - Sprocket: 5/8P 11T
89900199	Constellation Ranger - Sprocket: 5/8P 13T
89900200	Constellation Ranger - Sprocket: 3/4P 13T
89900204	Cobra Cruising Ranger
89900202	Mamba Ranger BH130
89900203	Mamba Ranger BH11

## Custom Pedestals

The Lewmar steering design team provides a unique service: they design and build pedestals for volume boat builders as well as one-off specials. If you have a specific design or need a specific pedestal solution, let our engineering team take care of your needs; we can provide a total package from the pedestal design to a delivered product ready to install.

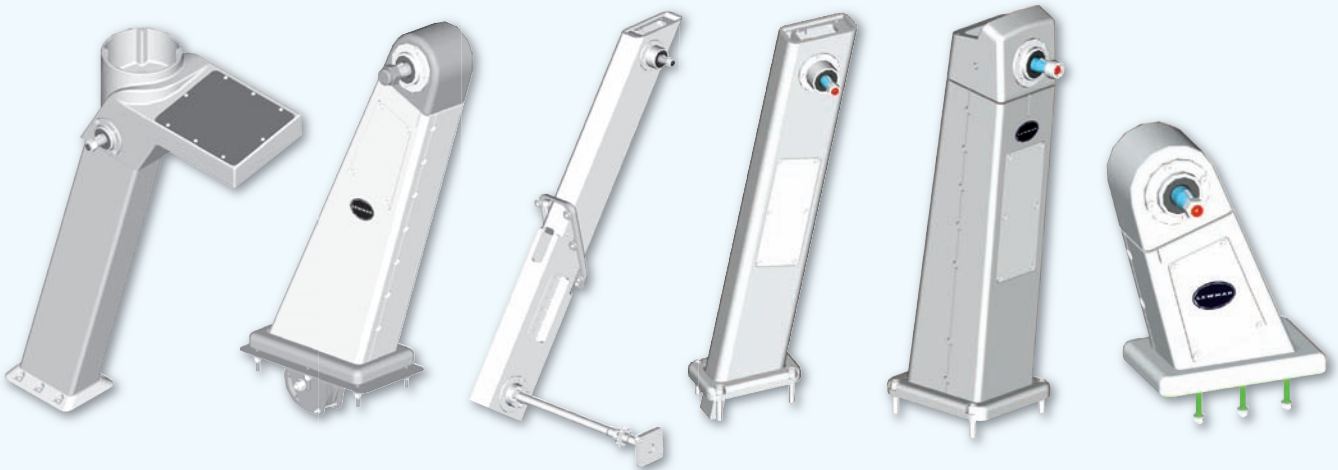

# Pedestal Accessories

## Compasses

The Lewmar 135 Compass is a stylish, precision instrument to complement any cockpit. The high-quality compass is manufactured with precision components. The compass utilizes a real sapphire to ensure ultimate reliability and durability. The diaphragms, made of Viton®, are fully waterproof and absorb the fluid variations resulting from differing temperatures and air pressure. Every compass complies with rigorous vibration, temperature, stability and precision specifications.

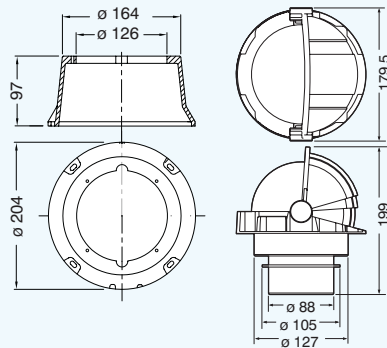

Part No	Description
89400000	Flush mount 135 compass with hood
89400001	135 compass complete with binnacle housing
89400002	Compass binnacle housing

## Features

- Apparent diameter of card: 130mm
- Flush mounting or pedestal mounting (with addition of a binnacle)
- Minimal flush mount depth
- Double lighting (12 or 24V mounting)
- Unique Lewmar binnacle
- Black card
- 5-year warranty



## Engine Control Mechanism

Lewmar offers engine and gear controls to complement the steering pedestal of your choice. The engine control designed exclusively for Lewmar is non-magnetic and can be guardrail or pedestal mounted without interfering with the compass.



89800013



Single Lever  
Engine Control

Part No	Description
89400109	Control Mech kit cranked handle and Fascia Plate
89400084	Engine control Housing to suit Morse SL3 Mechanism
89400133	Fascia Plate Control Mechanism
89400136	Handle Cranked Stainless Steel
89400118	Engine Control Housing to suit Volvo Mechanism
89400137	Mechanism Only (No Handle)
89400146	Fitting Kit for Control Mechanism
89400196	Control Mech Cranked Handle & Pod Assembly
89800013	Rubber button and plunger kit

## Features

- Housed in pod
- Guardrail mounted
- Bulkhead mounted with fascia plate
- Exclusive design for Lewmar
- Non-magnetic
- 316 stainless steel cranked handle

# Guardrails

Lewmar guardrails are designed to protect the compass and pedestal and to provide assistance while moving about in the cockpit. Our wide range of straight, kickback and extended guardrails is manufactured from a 32mm/1.25" 316 stainless steel tube. The extensive choice of guardrails is complemented by our instrument pod range; see pages 196-197.

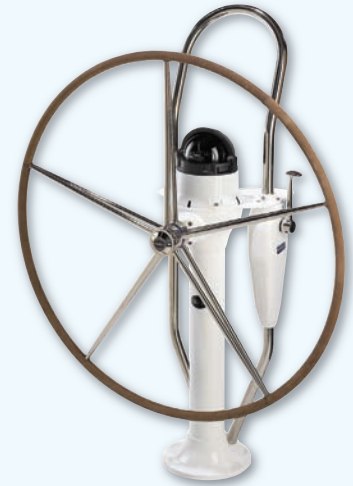

## Enguard Guardrail Kits

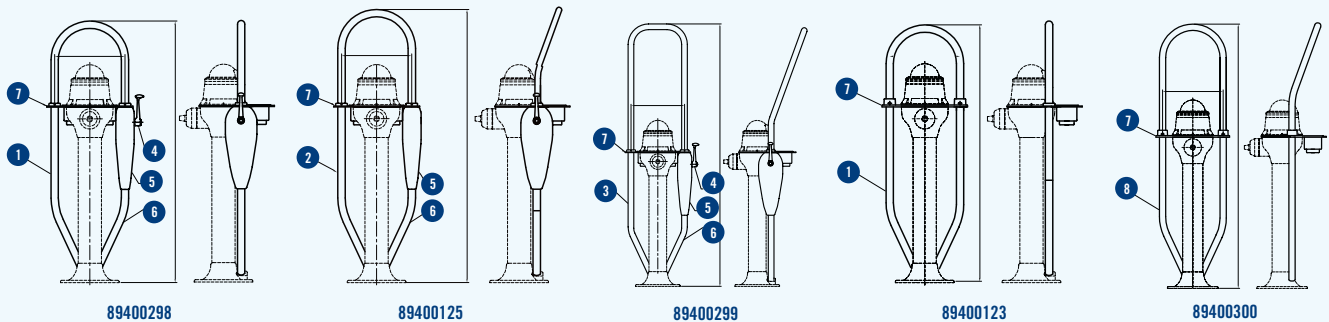

1 - 9 Individual parts 1-9 can be ordered separately

## Enguard Guardrail Kits

Part Number	Description
89400298	Enguard Guardrail Kit – Straight Guardrail, Engine Pod, Control Mechanism (Stbd), Top Plate & Cup holder
89400125	Enguard Guardrail Kit – Guardrail with Kickback, Engine Pod, Top Plate & Cup holder
89400299	Enguard Guardrail Kit – Super Extended Guardrail with Kickback, Engine Pod, Control Mechanism (Stbd), Top Plate & Cup holder
89400123	Enguard Guardrail Kit – Full Straight Guardrail, Top Plate & Cup Holder.
89400300	Enguard Guardrail Kit – Full Guardrail with Kickback, Top Plate & Cup Holder.

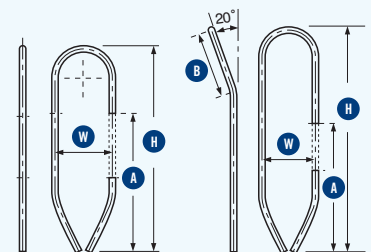

## Enguard Guardrail Spares

Key	Part Number	Description	H		A		W		B		20° kickback
			mm	in	mm	in	mm	in	mm	in	
1	89400031	Guardrail Straight - STBD	1097	43 3/16	740	29 1/8	305	12	-	-	
	89400032	Guardrail Straight - PORT									
2	89400033	Guardrail Kickback - STBD	1293	50 7/8	740	29 1/8	305	12	378	15	Yes
	89400034	Guardrail Kickback - PORT									
3	89400035	Guardrail Extended Kickback - STBD	1458	57 3/8	740	29 1/8	305	12			Yes
	89400036	Guardrail Extended Kickback - PORT									
4	89400109	Control Mechanism									
5	89400084	Engine Pod									
6	89400120	Drop Tube									
7	89400122	Top Plate & Cup Holder									
8	89400261	Full Guardrail - Straight	1097	43 3/16	-	-	305	12	-	-	
9	89400260	Full Guardrail - Kickback	1293	50 7/8	-	-	305	12	378	15	Yes

## Reliant & Royale Guardrail Kits

Part Number	Description
89400045	Std straight guardrail
89400046	Kickback rail
89400047	Extended kickback rail

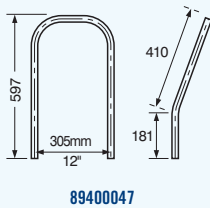
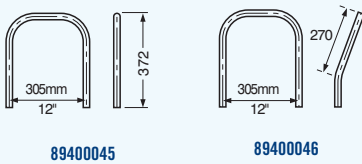

## Integra Guardrail Kits

Part Number	Description
89400361	Std Integra guardrail
89400362	Extended Integra guardrail
89400363	Extended Integra guardrail

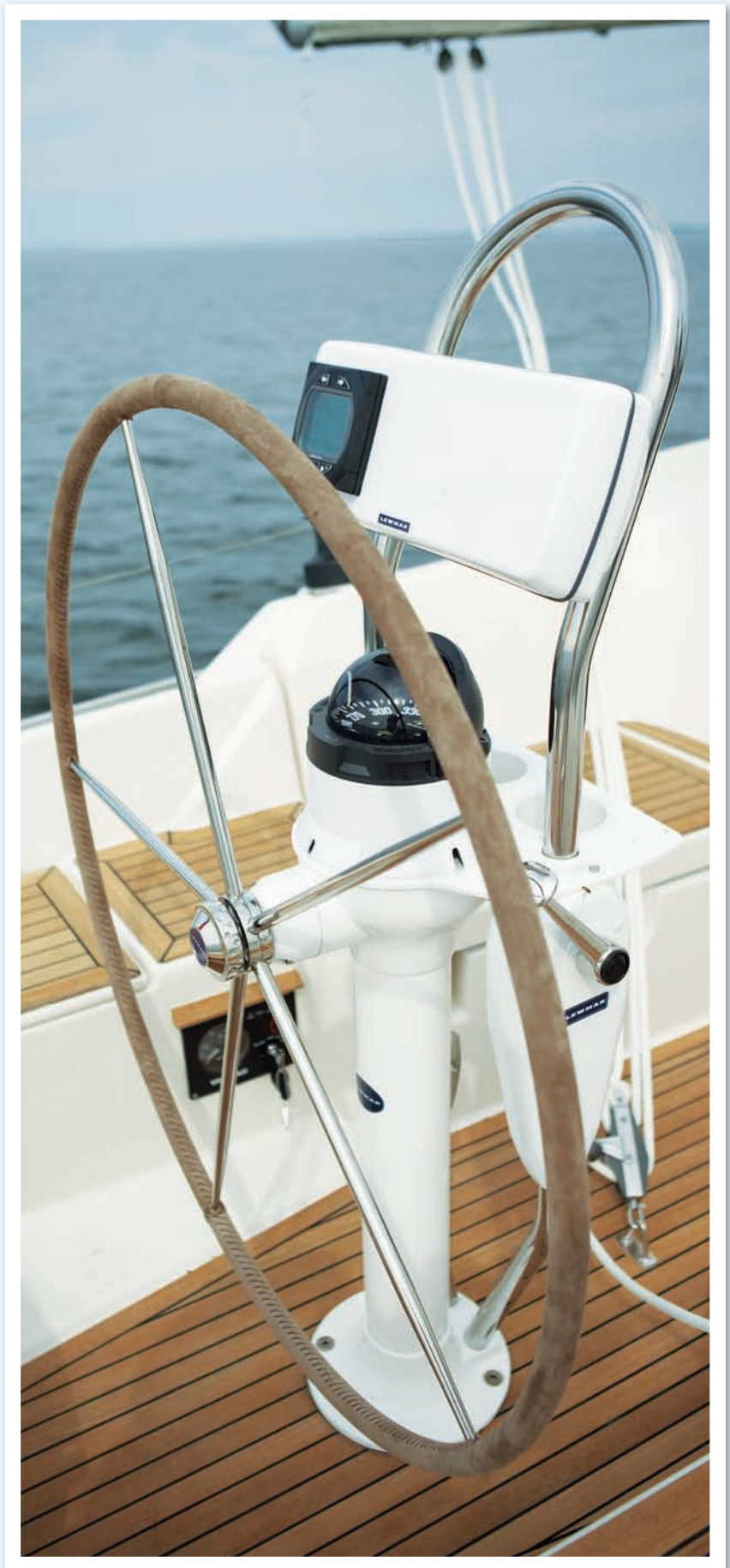

# Instrument Pods

Display your instruments in an easily accessible and attractive Lewmar Instrument Pod. Our comprehensive range of pods is designed to complement Lewmar pedestals. The pods are available as either retrofit accessories or as a complete assembly, and can house most sizes of yachting instruments, radars and chartplotters. Each one comes with fitting instructions and fasteners for easy, drill-and-tap installation.

## Extended Compact Pod

- Manufactured from thermoformed uPVC
- Available for the 304mm/12" center guardrail only
- Suitable for instruments 256mm/10" wide x 137mm/5" high x 75mm/3" deep

**89400218** Extended Compact Pod to suit 304mm/12" Center rail



**89400218**  
Extended Compact Pod

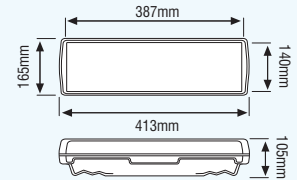

## Single Pod

- Manufactured from thermoformed uPVC
- Allows for one single instrument
- Dashboard mount or pedestal guardrail mount with s/s pod arm
- Instrument pod will swivel through 180°
- Pod arm will fit 28.6mm/1 1/8" and 32mm/1 1/4" diameter guardrail tubes
- All wiring of products mounted to the pod arm/instrument housing are hidden internally

**89400329** Pod Single with s/s Pod Arm

**89400330** Pod Single Cockpit-Dashboard Mount



**89400330**  
Single Pod

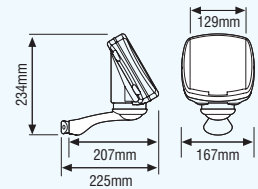

## Tandem Vertical Pod

- Manufactured from thermoformed uPVC
- Allows for 2-3 single instruments
- Dashboard mount or pedestal guardrail mount with s/s pod arm
- Instrument pod will swivel through 180°
- Pod arm will fit 28.6mm/1 1/8" and 32mm/1 1/4" diameter guardrail tubes
- All wiring of products mounted to the pod arm/instrument housing is hidden internally

**89400355** Pod Tandem Cockpit-Dashboard Mount

**89400356** Pod Tandem Vertical Mount with Pod Arm



**89400356**  
Tandem Vertical Pod

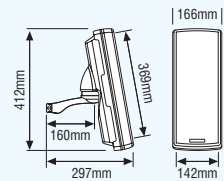

## Classic Pod

- Fits directly to the Enguard and Classic style pedestals, via a special top plate
- Offers increased mounting space for instruments on the pedestal
- Available with kickback guardrail for the inclusion of additional instrument pod options

**89400100** Classic Pod



**89400100**  
Classic Pod

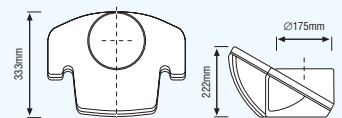



## Radar Multipod

- Manufactured in thermoformed uPVC
- Allows for the installation of 1x radar or similar, plus 4 industry standard instrument displays
- Available for the 304mm/12" center guardrail only

**89400274** Radar Multipod for 304mm/12" Guardrail



**89400274**  
Radar Multipod

**89400274**

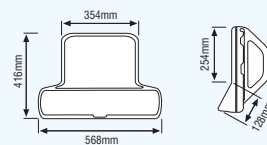

## Radar Swivel Mount & Guardrail Pods

- Manufactured from thermoformed uPVC
- 178mm/7" Pod: Allows for 1x Radar with 7" screen color version
- 254mm/10" Pod: Allows for 1x Radar/Chart Plotter 10" screen color version
- Swivel base mount or guardrail mounting 304mm/12" centers

**89400204** Radar Pod 178mm/7" c/w Swivel base

**89400222** Radar Pod 178mm/7" for 304mm/12" Guardrail

**89400205** Radar Pod 254mm/10" c/w Swivel base

**89400223** Radar Pod 254mm/10" for 304mm/12" Guardrail



178mm/7" Pod **89400204**  
254mm/10" Pod **89400205**  
Radar Swivel Mount &  
Guardrail Pods

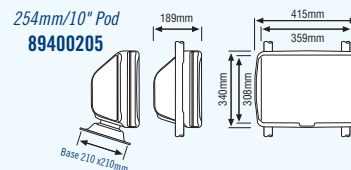
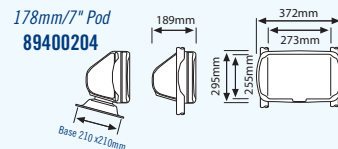

## Large Radar Swivel Mount & Guardrail Pods

- Manufactured from thermoformed uPVC
- Swivel base mount or guardrail mounting 304mm/12" centers
- Suitable for Raymarine E 120

**89400371** Large Radar Pod c/w Swivel base

**89400372** Large Radar Pod for 304mm/12" Guardrail



**89400371**  
**89400372**  
Large Radar Swivel Mount &  
Guardrail Pods

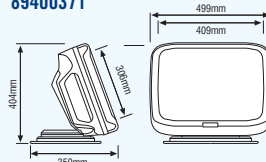
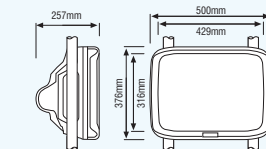

**89400372**

## Multipod

- Manufactured as a thermoformed uPVC molding
- Available for 304mm/12" and 241mm/9 1/2" center guardrails
- Offers the ability to fit 4 x 110mm square industry standard instruments

**89400200** Multipod for 241mm/9 1/2" Guardrail

**89400203** Multipod for 304mm/12" Guardrail



**89400200 / 89400203**  
Multipod

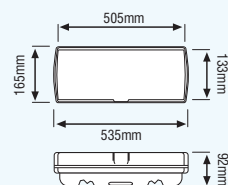

## LED Instrument Pod Cockpit Light

- Factory fitted to pod or optional accessory
- 10–33 Volt DC power required
- Waterproof sealing gasket provided

**89400206** Lamp Pod 10–33 volt LED



**89400206**  
LED Instrument Cockpit Light

## Stainless Steel GPS/Mobile Phone Holder

- Manufactured from 316 investment cast stainless steel
- Pod arm will fit 1", 1 1/8" and 1 1/4" diameter guardrail tubes
- All wiring of products mounted to the pod arm are hidden internally

**89400328** Stainless Steel GPS/Mobile Phone Holder



**89400328**  
Stainless Steel GPS/Mobile Phone Holder



# Cockpit Living & Steering Accessories

## Composite Table

Lewmar offers the Composite double-leaf folding table, manufactured from uPVC with a high strength composite core.

- Double-leaf fold out
- High-strength uPVC compact core
- Luxury finish

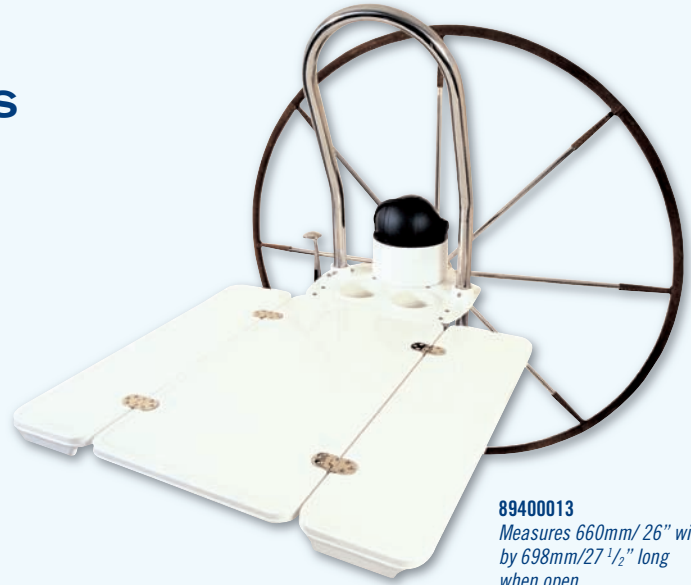

**89400013**  
Measures 660mm/ 26" wide by 698mm/27 1/2" long when open.

## Composite Tables

### Double-Leaf DIY Ready

Part Number	Description
89400013	Table Composite double-leaf with mounting kit for Enguard pedestal
89400014	Table Composite double-leaf with mounting kit for Reliant pedestal
89400015	Table Composite double-leaf with mounting kit for Athena pedestal
89400024	Table Composite double-leaf with mounting kit for Royale pedestal
89400409	Table Composite double-leaf with mounting kit for Integra pedestal

## Teak Tables

This three-leaf cockpit table in teak is available to suit all pedestal types and is supplied as standard with bracket, support and easy fitting instructions. When not in use, the table can be folded up against the forward edge of the pedestal.

- All Teak from sustainable forests
- Suits all pedestal types
- Quick-release hinge for simple storage
- Folds against pedestal



Measures 660mm/26" wide by 698mm/27 1/2" long when open.

## Solid Teak Tables Double-Leaf with Fitting Kits

Part Number	Description
89400283	Table Kit for Classic Pedestal unvarnished
89400284	Table Kit for Enguard Pedestal unvarnished
89400285	Table Kit for Reliant/Athena Pedestal unvarnished
89400286	Table Kit for Royale Pedestal unvarnished
89400365	Table Kit for Integra Pedestal unvarnished

## Fitting Kits only for Teak Tables

Part Number	Description
89400009	Classic pedestal DIY table fitting kit
89400117	Enguard pedestal DIY table fitting kit
89400011	Reliant pedestal DIY table fitting kit
89400192	Royale pedestal DIY table fitting kit
89400410	Integra pedestal DIY table fitting kit



Canvas Storage Bag

## Canvas Storage Bag

Part Number	Description
89400291	Canvas Storage Bag for Tables

## Mug Holders

Part Number	Description
89400003	Composite Mug Holder snap on



**89400003**  
Composite Mug Holder - Snap On



## Stainless Steel Cockpit Locker Latch

The Lewmar locker latch is a high-quality product designed for any boat. Easy operation via a winch handle.

### Features

- 316 investment cast product
- Easy installation
- Watertight 'O' ring seal
- Easy operation via winch handle
- Adjustable deck thickness



**89400061**  
Stainless Steel Cockpit Locker Latch

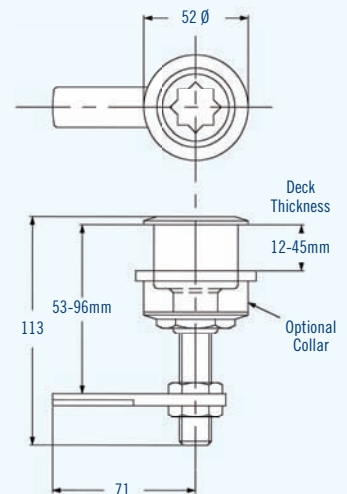

# Steering Systems

Lewmar offers a comprehensive range of steering equipment based on 3 different mechanical concepts.

- **Constellation™** - Wire Steering
- **Cobra™** - Rack & Pinion
- **Mamba™** - Rotating Torque Tube & Bevelhead

This product portfolio offers today's boat builders a solution for any steering installation.

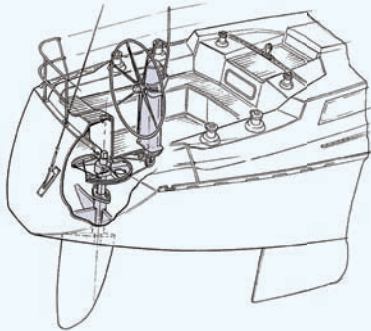

## Constellation™ – Wire Steering

Wire steering systems are suitable for yachts from 7m/25' to Maxi's. This diversity has enabled us to develop the Constellation™ system with feedback from various types of boat builders. Wire systems are ideal for aft cockpit installations, either single or tandem. Wire-in conduit systems are also available for center cockpit installations. The conduit system overcomes the difficulties that are experienced when using open wire in center cockpit installations.

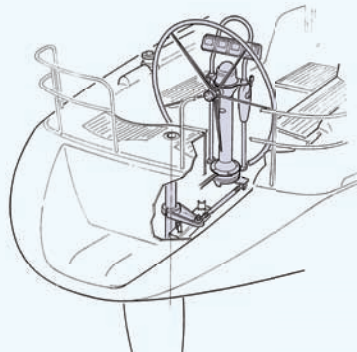

## Cobra™ – Rack & Pinion

Cobra™ uses rack and pinion in the head of the pedestal to provide the necessary mechanical advantage required for sensitive steering. Cobra™ has been designed for use in aft cockpit sailboats and is a world leader in its field. Lewmar also offers customized Cobra™ systems for use in non-aft cockpit applications.

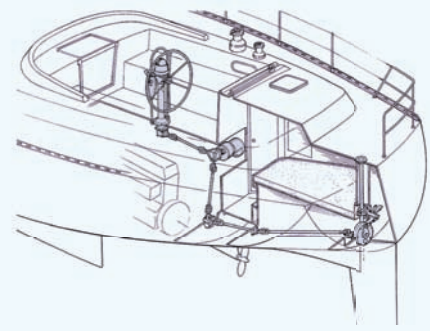

## Mamba™ – Rotating Torque Tube & Bevelhead

The ultimate steering system providing feedback and strength: both features that are unique to gear box and bevelhead steering systems. Mamba™ is a suitable steering system for a diverse range of sailboats from blue water cruisers to America's Cup contenders. It offers unique features such as power assisted steering while retaining versatility in the type of installation in which it can be used (i.e. Tandem systems.)

Steering manuals and installation guides for the Constellation, Cobra and Mamba systems can be found on the Lewmar website [www.lewmar.com](http://www.lewmar.com)



# Constellation™ Systems

Constellation is made up of a complete range of wire steering systems, offering award winning design and high-quality construction for vessels up to 18m/60'. The systems have been developed in conjunction with both production boat yards and the world's racing community.

All aluminum parts are etched, alochromed and stoved using powder coated polyester resins.

## OPEN Wire Systems

### Constellation™ Aft Cockpit Radial Steering Systems

The simplest wire system available for aft cockpit yachts with vertical, or near vertical, rudders using a radial quadrant in conjunction with a cross-wire idler, (universal idler if the pedestal is mounted aft of the rudder stock). Dependent on sheave and quadrant sizes, this equipment can be employed on sailing yachts up to approximately 18m/60'.

Please note the sheaves are fully adjustable in the angular mode to obtain perfect lead from sheave to quadrant. The splay angle is dependent on:

A) Distance from pedestal center to rudder stock

B) Quadrant diameter

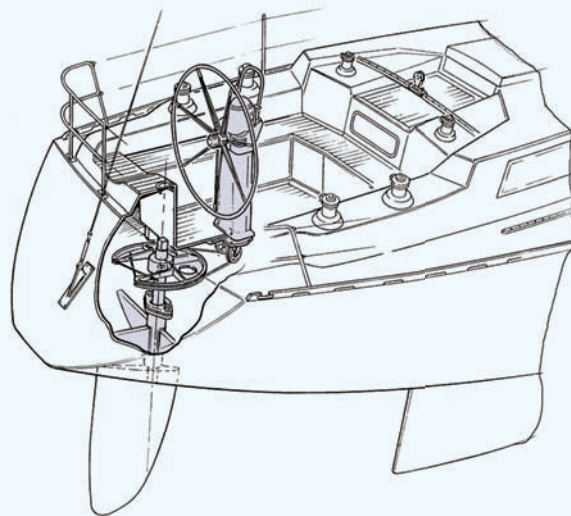

*A typical aft cockpit radial wire system incorporating 260° radial quadrant crosswire idler.*

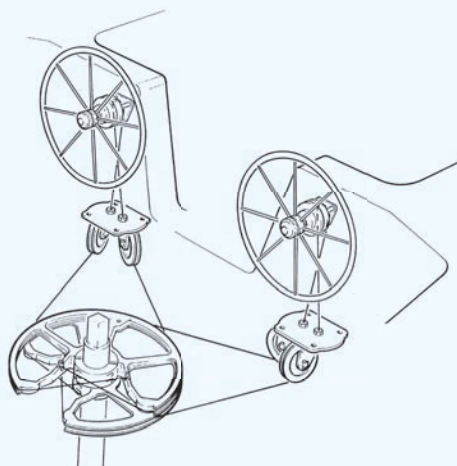

*Typical twin wheel Constellation™ installation incorporating bulkhead steers and beveled cross-wire idlers.*

### Constellation™ features

- Steering shaft supported in triple high-efficiency ball bearings, ensuring no axial and radial play
- Cross-wire idlers, beveled and adjustable to ensure perfect cable alignment
- Composite construction quadrants for maximum reliability and compactness
- Range of terminal units, sheaves, bulkhead steerers, quadrants and accessories
- Efficient installation
- Pedestal sprocket options, dependent on boat size: 5/8P 11T, 5/8P 13T or 3/4P 11T
- Electrostatically applied, polyester coating for maximum corrosion protection
- Integrated autopilot drive kit for mounting drive units



# Wire-in Conduit Systems

Due to their ease of installation, wire-in conduit systems have largely replaced open wire for center cockpit yachts.

Advances in conduit technology have resulted in Constellation systems that are simple to install and easy to maintain.

Self contained sheave assemblies have been developed to fit into the conduit route, eliminating the requirement for re-enforced pads.

Lewmar offers a range of components to complete your wire-in conduit installation, including conduit end fittings, conduit greasers and terminal units to align the cables with the quadrants.

## Features

- Simple to install
- Ultimate reliability
- Pedestal or bulkhead mounting for wheels
- Heavy duty double armored conduit with low-friction liner to ensure efficiency
- In-line conduit greasers

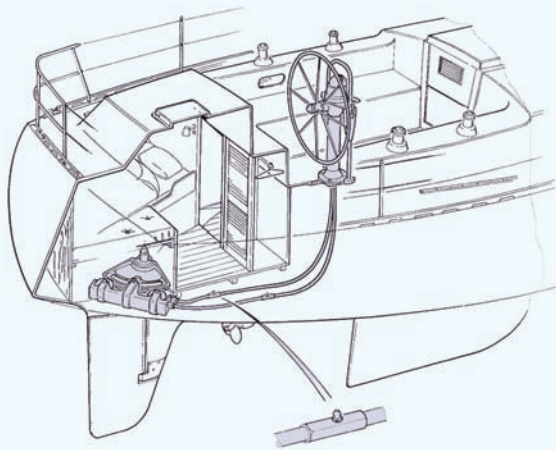

*In-line conduit greasers*

Most common conduit installation for center cockpit yachts up to 12m/40'. To achieve the maximum sensitivity and life from a conduit system please follow the following rules:

1. Keep the number of bends to a minimum.
2. Do not exceed 270° of total curves.
3. Avoid 'S' bends.
4. Orientate the quadrant to achieve the best conduit lead.
5. Minimum bend radius 200mm/8".

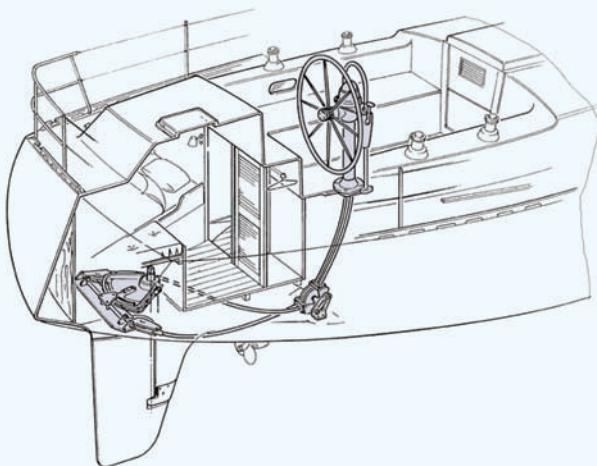

A typical 15m/50' center cockpit installation, utilizing conduit from the pedestal to the conduit sheave adaptor. The steering then follows the curve of the hull in conduit, terminating at an articulated terminal unit.

# Combination Conduit / Open Wire Systems

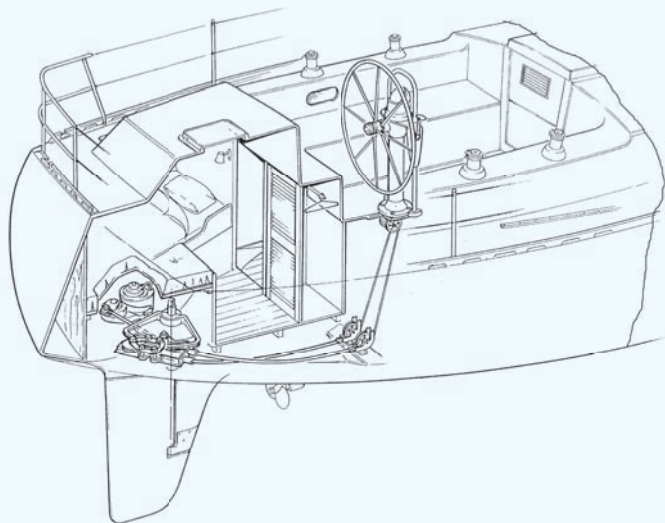

Example where the quadrant is offset to starboard and the tangential terminal unit has been fitted. A universal idler at the bottom of the pedestal using open wire to conduit adaptors is illustrated as an option. In this instance therefore, the conduit adaptors have to be rigidly installed.



# Constellation™ Bulkhead, Shelf and Self-aligning Steerers

The Bulkhead steerer incorporates twin high-efficiency ball races, which are double sealed and pre-lubricated for a long and maintenance-free life.

## Self-aligning Steerer

- Self-aligning ball to take up misalignment or draft angle when installing within a console
- Compact installation with a minimum distance of 100mm/4" between bulkhead faces
- Available with sliding sprocket to aid line-up with multiple sheaves
- Steering shaft supported by high-efficiency, sealed-for-life bearings
- Through-shaft mounted friction brake
- Forward and aft flange housing manufactured in polymer composite material

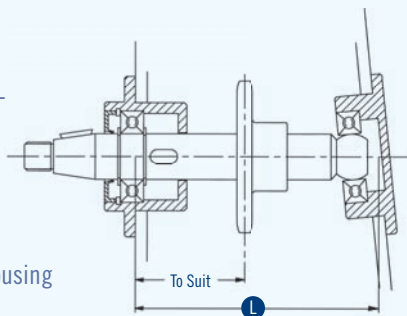

Self-aligning Steerer

## Features

- Incorporates twin high-efficiency, double sealed ball races
- Rapid and simple installation
- Stainless steel backing plate for maximum rigidity
- Variety of sprocket sizes
- Custom steering shafts are available

## Self-aligning Steerer

Part Number With Brake	Part Number No Brake	Sprocket Type	Dimension L
<b>Standard Self-aligning Steerer</b>			
89100***	89100***	5/8P-11T	100 to 300mm
89100***	89100***	5/8P-13T	101 to 300mm
<b>Stainless Steel Self-aligning Steerer</b>			
89100***	89100***	5/8P-11T	100 to 300mm
89100***	89100***	5/8P-13T	101 to 300mm

## Shelf Steerer

For a mounting alternative, the Shelf Steerer is available.

- Suitable for installation inside an existing pedestal
- Can be mounted on a horizontal surface
- Available with a wide range of sprocket options
- Steering shaft supplied as standard with a secondary fixing position to fit an autopilot sprocket

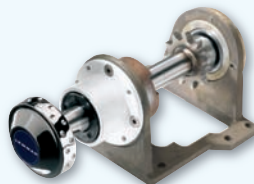

Part Number	Sprocket Type
89100000	5/8P-11T
89100001	5/8P-13T
89100002	5/8P-15T
89100003	3/4P-11T

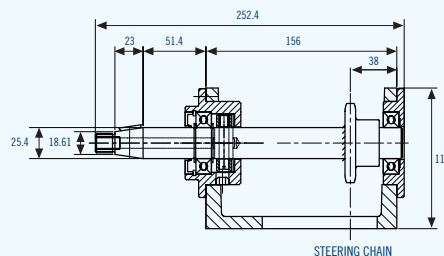

Shelf Steerer

## Quick-mount Bulkhead Steerer

- The unit comes complete with a through shaft brake, autopilot stub shaft take-off
- The steerer is manufactured in stainless steel and powder coated to a high-gloss finish
- The steering shaft is supported by apre-lubricated sealed ball race bearing, which provides low friction



Part Number	Sprocket Type
89100004	5/8P-11T
89100006	5/8P-13T
89100008	5/8P-15T
89100010	3/4P-11T

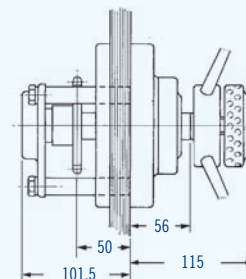

Quick-mount Bulkhead Steerer



# Constellation™ Chain and Wire Assemblies

## Breaking Strength

The figures shown in the tables below indicate the minimum breaking strength of Lewmar cables and chain. Due to the reduction in strength caused by cable fatigue over time, the maximum loading (torque) should never exceed 25% of the breaking strain shown. For example, a 305mm/12" radius quadrant used in conjunction with 6mm/0.23" wire is suitable for the following maximum rudder torque.

**Torque** = Breaking Strain x Radius x Safety Factor

(metric) = 2040Kg x 0.305m x 0.25  
= 155 mKg

(imperial) = 4500lb x 12" radius x 0.25  
= 13500 in.lb

## Steering Cable 7x19 Stranded Stainless Steel

Part Number	Cable Diameter		Breaking Strain	
	mm	in	kg	lb
89100077	5	0.1	1406	3100
89100078	6	0.2	2040	4500
89100079	8	0.3	3628	8000
89100080	10	0.4	5306	11700



Wire and Chain assembly



Pre-swaged cables

## Non-Magnetic Stainless Steel Roller Chain Assemblies

Part Number	ANSI SPEC	Pitch in	Breaking Strain	
			kg	lb
89100090	ANSI 50	5/8	2267	5000
89100093	ANSI 60	3/4	3175	7000
89100096	ANSI 80	1	4988	11000

## Conduit

Part Number	Description
89100069	Conduit (sold per meter)
89100116	Conduit end fitting

## Pre-swaged Cables

Part Number	Description
89100401	Cable Set 6mm Swaged 2000mm
89100403	Cable Set 6mm Swaged 3000mm
89100405	Cable Set 6mm Swaged 4000mm
89100407	Cable Set 6mm Swaged 5000mm
89100409	Cable Set 6mm Swaged 6000mm
89100411	Cable Set 6mm Swaged 7000mm
89100413	Cable Set 6mm Swaged 8000mm
89100415	Cable Set 6mm Swaged 9000mm

## Features

- Precision engineered in non-magnetic stainless steel
- Two off-master links for easy connection to the cable
- Custom length chain sets available on request
- Cable supplied in 7 x 19 stainless steel stranded construction
- Cable can be supplied to be finished with eyebolts and thimbles
- Fully assembled with pre-swaged eyebolts



## Constellation™ Quadrant, Sprocket & Chain Kit Specification Table

Part Numbers			Sprocket Size vs turns H0/H0 for 72° Rudder Travel			
APPROPRIATE CHAIN KIT						
5/8" P Sprocket	3/4" P Sprocket	Quadrant Type	5/8" P 11T	5/8" P 13T	5/8" P 15T	3/4" P 11T
89100090	89100093	152mm/6" radius 260°	1.08	0.92	0.79	0.9
89100090	89100093	190mm/7.5" radius 80°	1.35	1.14	1.0	1.12
89100090	89100093	203mm/8" radius 260°	1.44	1.22	1.06	1.20
89100090	89100093	228mm/9" radius 260°	1.62	1.37	1.18	1.35
89100090	89100093	254mm/10" radius 260°	1.8	1.52	1.32	1.50
89100090	89100093	304mm/12" radius 80°	2.2	1.86	1.61	1.80
89100090	89100093	304mm/12" radius 260°	2.2	1.86	1.61	1.80
89100091	89100094	381mm/15" radius 80°	2.71	2.29	1.98	2.25
89100091	89100094	381mm/15" radius 260°	2.71	2.29	1.98	2.25
89100091	89100094	457mm/18" radius 80°	3.25	2.75	2.38	2.70
89100091	89100094	457mm/18" radius 260°	3.25	2.75	2.38	2.70
89100092	89100095	508mm/20" radius 80°	3.61	3.05	2.64	3.00
89100092	89100095	609mm/24" radius 80°	4.35	3.68	3.19	3.60
89100100	89100096	762mm/30" radius 80°	5.44	4.60	4.00	4.50

Note: Other specific cable lengths are available upon request.

The table (left) illustrates the turns at the helm for a range of standard sprocket and quadrant sizes.

Lewmar Steering offers custom quadrants in 6082T6 alloy or composite up to 1020mm/40" radius. We can also offer custom sprockets with any number of teeth in 15.87mm/5/8" or 19.05mm/3/4" or 1"/25.4mm pitch stainless steel or 60802T6 high-strength aluminum.

# Constellation™ Sheave Assemblies

Lewmar offers an extensive range of open wire sheave assemblies from 102mm/4", 127mm/5", 152mm/6", 203mm/8" and 254mm/10" diameters. For each size, Lewmar offers upright, flush, flat and articulated versions. Lewmar sheaves are available in bronze, aluminum and A100 glass reinforced nylon.

## Features

- 102mm/4" & 152mm/6" sheave assemblies are supplied with A100 glass reinforced, nylon sheaves, which are corrosion resistant
- 127mm/5" sheaves are available upon request
- The 203mm/8" and 254mm/10" versions incorporate anodized aluminum sheaves, housed in laser cut 316 grade stainless steel carriers
- High operation efficiency and sensitive steering operation – sheaves run on 45mm/1.77" caged roller bearings
- All open wire sheave assemblies incorporate wire guides to prevent cable jump



Single Articulated Sheave



Double Upright Sheave Assembly

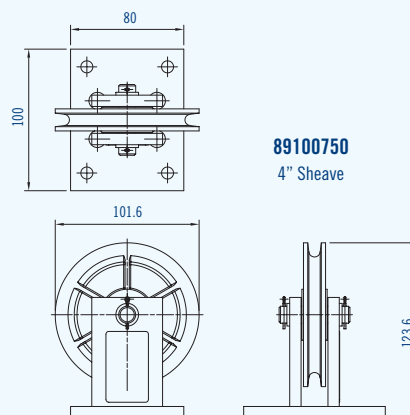

89100750  
4" Sheave

## Open Wire Sheaves

Part No Single	Part No Double	Sheave diameter		Description
		mm	in	
89100750	-	101	4	Upright
89100026	89100029	152	6	Upright
89100027	89100030	152	6	flat
89100028	89100031	152	6	Flush
89100032	89100033	152	6	Articulated

## Constellation™ Idlers

Lewmar Idlers are designed to prevent chafing when the cable straightens into the sheave track. The drawing (bottom right) demonstrates the advantage of Lewmar's beveled cross-wire idler plate.



Universal Idler



Cross Wire Idler

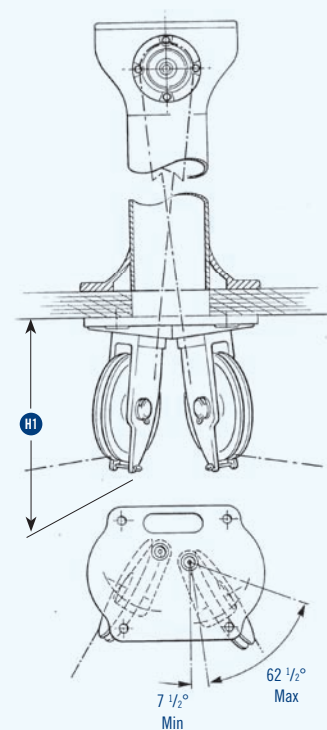

Illustration showing the flexibility of a Beveled Idler

Part Size Number	Idler Type	Sheaveø		Cableø	
		mm	in	mm	in
89100015	Cross-wire Idler	101	4	5	3/16
89100016	Universal Idler	101	4	5	3/16
89100018	Cross-wire Idler	127	5	5-6	3/16 - 1/4
89100019	Universal Idler	127	5	5-6	3/16 - 1/4
89100022	Cross-wire Idler	152	6	6	1/4
89100023	Universal Idler	152	6	6	1/4
89100024	Cross-wire Idler	203	8	8	5/16
89100025	Universal Idler	203	8	8	5/16



## Conduit Steerers

Part Number	Description
89100098	152mm/6" Single Conduit Sheave
89100099	152mm/6" Double Conduit Sheave



**89100098**  
6"/152mm Single Conduit to  
Sheave adaptor



**89100099**  
6"/152mm Double Conduit to  
Sheave adaptor

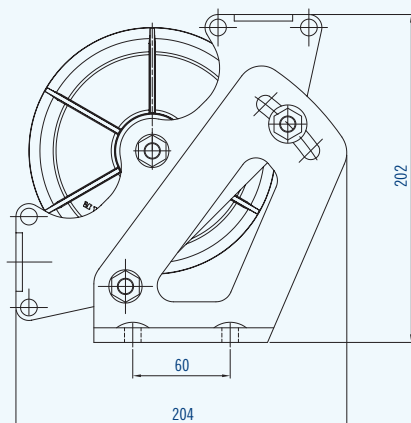
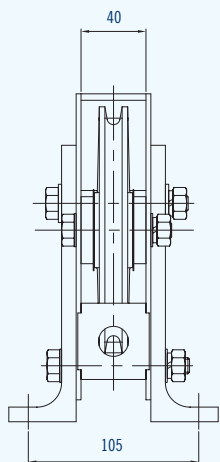

**89100098**  
Single Conduit Sheave

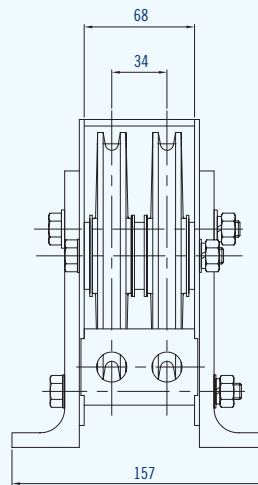

**89100099**  
Double Conduit Sheave

# Constellation™ Quadrants

Lewmar offers a range of unique, composite 80° and 260° quadrants.

## Features

- Fabricated from 6082 aluminum alloy
- Strong yet ductile, almost impossible to fracture under impact loading
- Compact, where transom space is restricted
- Attachment point for linear drives on larger quadrants
- Quadrants with integral stopping surfaces for use against the rudder stop
- Radial versions supplied pre-drilled for optional bolt on stop block
- Generous groove depths and a large guide bend radii, for longevity of the cable.
- 80° quadrants supplied with cable retaining pins to prevent cable jump

**Note:** Guidelines for suitable boat length/quadrant size combinations are based on typical boat design and may vary significantly dependent on boat displacement, rudder shape, wheel diameter, etc. It is important to verify your selection in conjunction with your Naval Architect. Typical boat lengths for 80° quadrants are based on cable-in conduit steering systems.



## 80° High Strength Quadrants

Part Number	Operating Radius		Maximum Bore Size $\phi$		Typical Boat Length		H1 Boss Height		H2 Boss Height		L1 Maximum Rad Width		L2 Maximum Rad Width	
	mm	in	mm	in	m	ft	mm	in	mm	in	mm	in	mm	in
89100058	190	7.5	80	3	10	32	60	2.4	35	1.3	195	7.7	290	11
89100059	228	9	80	3	9–11	30–37	60	2.4	35	1.3	233	9	350	13.7
89100060	305	12	80	3	10–13	36–42	60	2.4	35	1.3	308	12	456	18
89100061	305	12	100	4	10–13	36–42	60	2.4	35	1.3	308	12	456	18
89100062	381	15	80	3	12–15	40–48	60	2.4	35	1.3	382	15	564	22
89100063	381	15	100	4	12–15	40–48	60	2.4	35	1.3	382	15	564	22
89100064	457	18	100	4	14–16	45–52	60	2.4	35	1.3	465	18	718	28
89100065	457	18	125	5	14–16	45–52	100	4	42	1.6	465	18	718	28
89100066	508	20	125	5	15–19	50–62	100	4	42	1.6	512	20	815	32
89100067	609	24	125	5	18–24	60–80	100	4	42	1.6	615	24	938	37

**Note:** All above part numbers are for standard quadrants supplied pilot bored. Lewmar offers a machining service to supply the quadrant ready to suit the rudder stock of the boat. Please contact your Lewmar Distributor for part number and price prior to ordering.

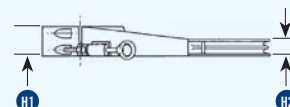
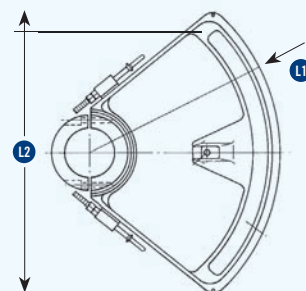

## 260° High Strength Quadrants

Part Number	Operating Radius		Maximum Bore Size $\phi$		Typical Boat Length		H1 Boss Height		H2 Boss Height		H3 Boss Height		L2 Maximum Rad Width	
	mm	in	mm	in	m	ft	mm	in	mm	in	mm	in	mm	in
89100049	152	6	80	3	10	32	60	2.3	48	1.8	60	2.3	155	6
89100050	203	8	80	3	9–11.5	30–38	60	2.3	48	1.8	60	2.3	210	8
89100051	254	10	80	3	10–13	35–42	60	2.3	48	1.8	60	2.3	260	10
89100052	254	10	100	4	10–13	35–42	60	2.3	48	1.8	60	2.3	260	10
89100053	305	12	100	4	12–15	40–50	60	2.3	50	2	62	2.4	315	12
89100054	381	15	125	5	14–18	45–60	100	4	86	3	98	3.8	390	15
89100055	457	18	125	5	17–24	55–80	100	4	86	3	98	3.8	470	18.5

**Note:** All above part numbers are for standard quadrants supplied pilot bored. Lewmar offers a machining service to supply the quadrant ready to suit the rudder stock of the boat. Please contact your Lewmar Distributor for part number and price prior to ordering.

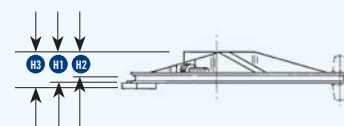
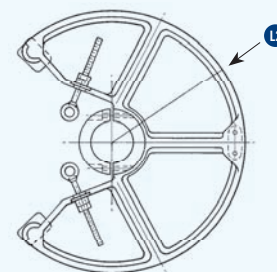

## Eye bolt tensioner kit

Eye bolt/cable tensioner are not supplied with quadrants and must be ordered separately.

89100569 Eye bolt tensioner kit for 5mm wire cable

89100196 Eye bolt tensioner kit for 6mm wire cable

# Articulated Terminal Units

Lewmar offers a range of terminal units to assist the alignment of the cables into the quadrant. The unique, articulated terminal unit provides easy routing of the conduits.

The sheaves on the articulated unit can be adjusted to a maximum 45° take-up angle from the horizontal. This unit greatly reduces the friction within the system, prolonging the life of both the cable and conduits. The unit is supplied complete with rudder stops and fully prepared for mounting.

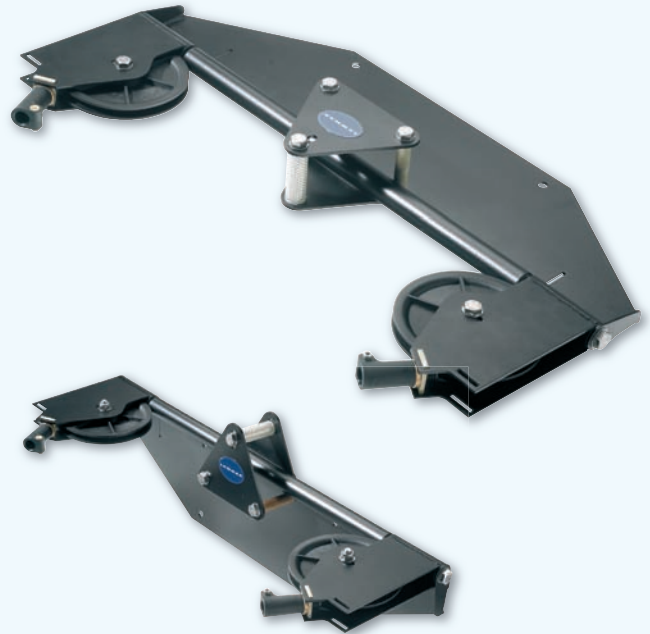

Part Number	Description
89100113	Articulated terminal unit to fit up to 12" quadrant
89100114	Articulated terminal unit to fit up to 18" quadrant
89100115	Articulated terminal unit to fit up to 24" quadrant

## Correct and incorrect installation of an Articulated Terminal Unit

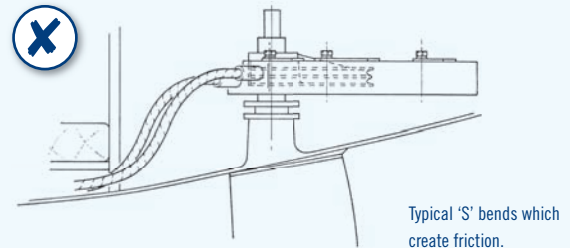
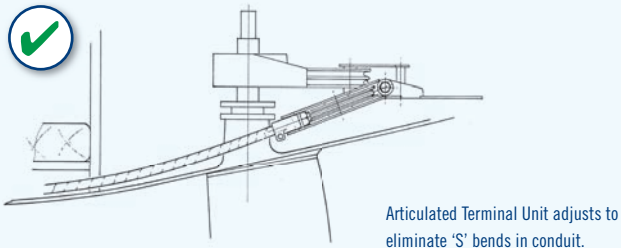

## Tangential Terminal Unit

Part Number	Description
89100111	2-turn Tangential Unit
89100112	152mm/6" Tangential Terminal Unit

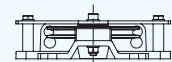
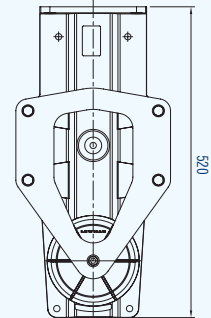
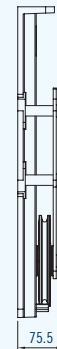
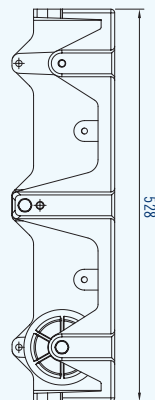
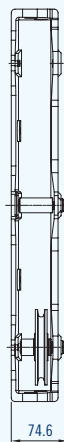
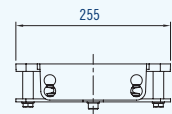
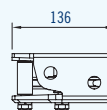

89100111

89100112



# Cobra™ Systems

With over 40 years of technological development, Cobra has become the first choice for boat builders worldwide for aft cockpit vessels.

Cobra systems are the world leader in terms of performance, reliability and appearance, for Rack and Pinion.

## Features

- Absolute precision and feel – as responsive as a tiller
- Simple installation
- Strong and light – no parts to fret, chafe or fatigue
- Minimum maintenance
- Smoother operation
- Greater torque capability
- Full CE Certification available



## Wide Angle Geometry

The lever geometry for Lewmar transmission systems is based on the principle of Wide Angle Geometry. This results in a very direct steering amidships and a more indirect and powerful steering at full rudder. Due to this unique feature, the total number of turns of the wheel on a transmission steering system can be reduced by 30-40% compared to a cable system with the same maximum rim loads. This effect is achieved by an unequal length of the output and tiller lever. The diagram to the right shows the mechanical advantage (lever reduction) in relation to the rudder angle. Around midships the reduction is quite constant, and above 15 degrees rudder the mechanical advantage nearly doubles compared to the midships advantage. The consequence of wide angle geometry is the offset angle of the levers in midships position. This offset angle is necessary to achieve the same travel to port and starboard. The offset angle varies with the distance from the output lever to the tiller lever. Offset angles can be avoided when the complete gearbox is put on an offset distance.

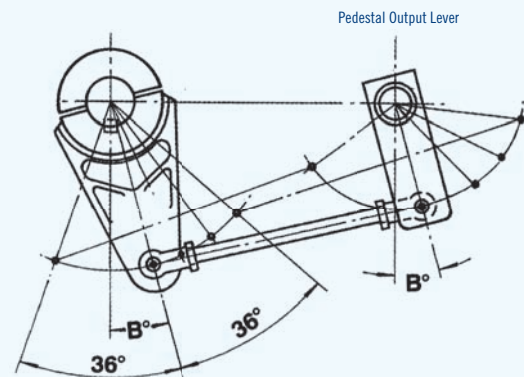

## Cobra™ Cruising

The principle of the Cobra™ steering system is based on the precision gearcut circular rack and pinion in the head of the pedestal, providing the necessary mechanical advantage. The quadrant gear is connected to a stainless steel downtube, at the base of which is an output lever. This connects to a similar lever, mounted on the rudder stock, via a fully adjustable draglink.

All shaft work is carried through high-efficiency sealed ball races, and the mesh of gears is controlled via shims under the input, eliminating any lost motion. The input socket also houses a powerful and progressive friction brake for dampening the wheel, when at anchor, for example.

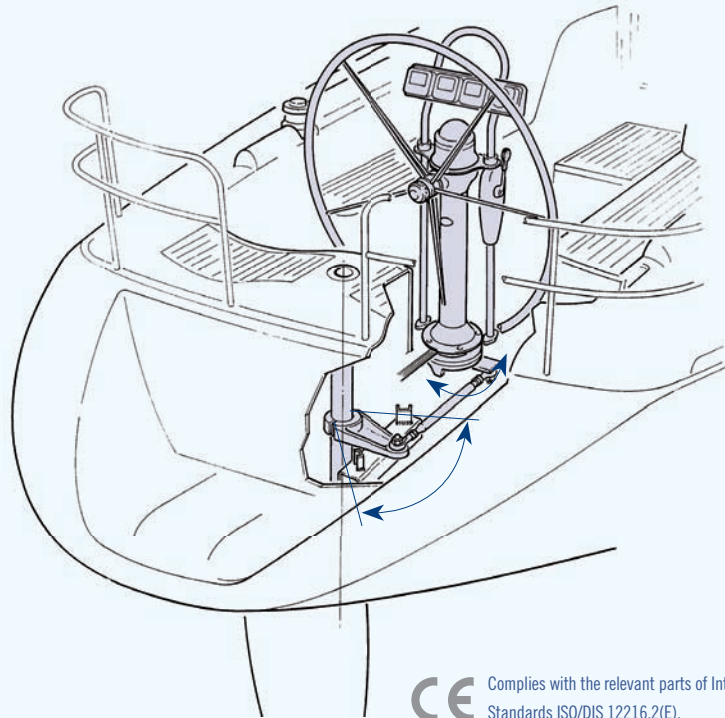

**CE** Complies with the relevant parts of International Standards ISO/DIS 12216.2(E).  
**Approved** This standard covers the applicable essential safety requirements of the Recreational Craft Directive 94/25/EC.

### COBRA CRUISING/COBRA OCEAN/COBRA

- Rated output load 12234 N
- Maximum rudder torque at midships 252 Kgf.m
- Maximum rudder torque at full lock 474 Kgf.m

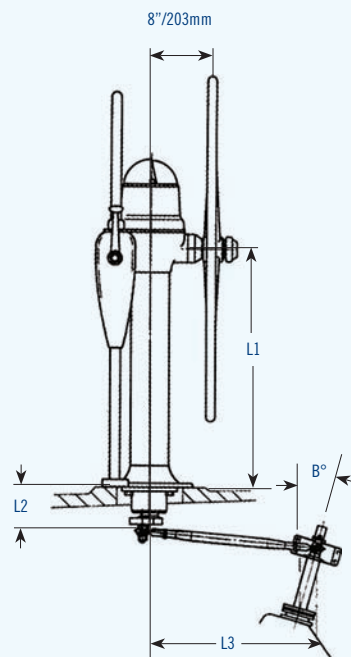

## Cobra™ Installation Guidelines

**L1** Standard pedestal height  $L1 = 710\text{mm}/28"$ . Minimum possible height =  $178\text{mm}/7"$ , maximum possible height  $915\text{mm}/36"$ .

**L2** Standard under deck dimension  $L2 = 102\text{mm}/4"$ . The minimum dimension is governed only by the thickness of the cockpit sole. Where an extended  $L2$  under deck is required, it may be necessary to also add a torque snubber plate, as seen on page 213.

**L3** The distance between the center of the pedestal and the rudder stock,  $L3$  can vary between  $120\text{mm}/5"$  and  $2000\text{mm}/79"$ . Draglinks are made to specification and are adjustable by  $20\text{mm}/0.78"$  upon installation.

The draglink should not exceed an angle of  $5^\circ$  from the horizontal.

A standard Cobra installation can accommodate a rudder rake up to a maximum of  $30^\circ$ . This does, however, depend on the boat size and type, and the length of  $L3$ . Where this angle exceeds  $20^\circ$ , please consult our technical department.

As standard, all levers are mounted to the starboard side and the pedestal is mounted forward of the rudder stock.



# Cobra™ Racing

Cobra™ Racing is designed specifically for racing and fast cruising yachts up to 17m/55', providing the ultimate in feel and responsiveness.

## Features

- Incorporates uprated components to handle the higher torque demands of a large wheel installation
- More direct gear ratio offering 1.5 turns lock to lock
- Can be reduced to less than 1 turn where required
- Larger diameter pinion for greater strength and more direct steering
- Light, strong pedestal shell incorporating 101mm/4" diameter tube
- Uprated gear quadrant in super nickel aluminum bronze



Cobra™ Racing in Enguard Pedestal

# Cobra™ Ocean

Designed for Blue Water yachts, with smaller wheels requiring a greater number of turns lock to lock, while offering the same superb feel and simple, compact installation as other Cobra™ variants.

## Features

- For yachts up to 18m/60'
- Suitable for maximum rudder torque of 4905Nm/3618 lb ft
- Additional space for a larger gear set
- 2.4 turns lock to lock
- Larger bearings and a 60mm/2.3" stainless steel down shaft
- Royale and Ranger pedestals specific to the Cobra™ Ocean system



*Cobra™ Ocean available with Royale pedestal*



# Cobra™ System Customized for specific installations

A Cobra system can be customized for twin rudder installations, bridge deck consoles, transom mount rudders and center cockpit vessels. Cobra™ offers a simple steering solution for this arrangement that ensures the rudders remain in phase and Ackerman effect can be achieved.

## Features

- One-piece Power input assembly, easy maintenance and gear adjustment
- High-efficiency double sealed deep groove ball bearings
- Powerful and progressive, front mount friction brake
- One-piece heavy duty stainless steel down tube
- Computer optimized gear quadrant design
- Gear quadrant secured via twin
- 10mm/0.39" stake pins with double shear
- High-strength stainless steel output level welded to down shaft
- Stainless steel rose jointed draglink
- Nybrol gear quadrant and pinion for ultra high strength
- Ability to withstand shock loads

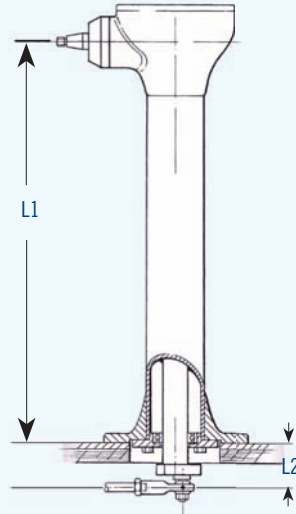

Frequently the space directly below the cockpit floor is limited and this special bearing arrangement reduces the intrusion into the accommodation.

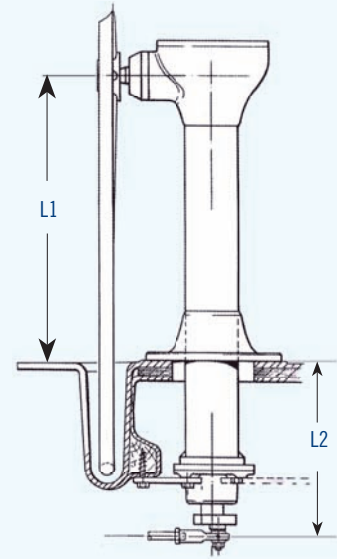

This illustrates the use of a wheel trough and shortened height pedestal, which is particularly common on Cobra™ Racing installations where large wheels are fitted.

Besides giving more mechanical purchase, the large diameter wheel enables the helmsman to sit out and still reach the helm. Please note that the use of a torque snubber plate may be necessary to counteract the extra pitching movement caused by the large L2 dimensions (greater than 15mm/6").

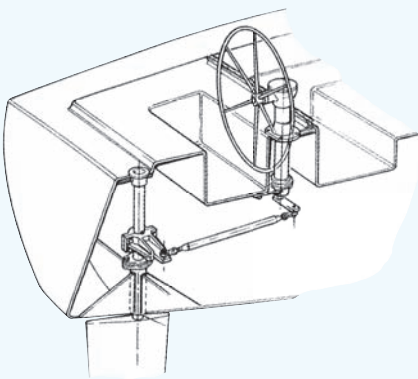

A further variation on the extended under deck setup is shown here. In this case, the pedestal is mounted on a bridge deck. The minimum height between the base and center of the wheel shaft is 178mm/7", and the base flange can be cropped on its fore and aft face to reduce the width it occupies.

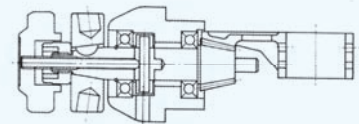
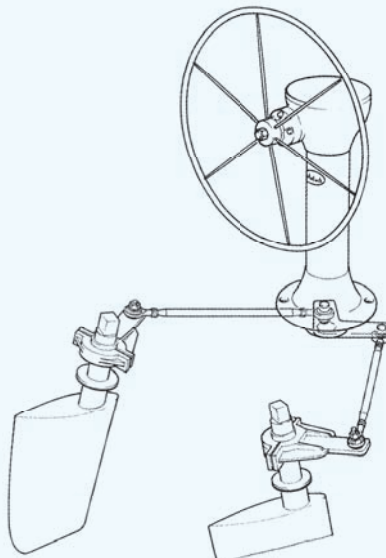

## The PowR™ Input cartridge.

This input socket design prevents the quadrant gear from lifting the pinion gear under high load conditions.



## Stop Rings

Limiting the amount of rudder travel is essential on all steering arrangements. The Cobra™ system provides an alternative, simpler-to-install device than conventional rudder stops – the stop ring.

The stop ring, mounted directly below the pedestal, ensures that the output lever travel does not exceed the designed limit. Stops should operate adjacent to operating centers.

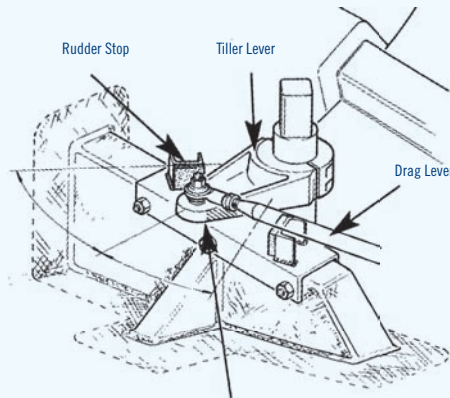

Stops should operate adjacent to operating centers.

Additional rudder stop can be fitted to tiller lever if a stop ring cannot be installed



## Rod Ends

Part Number	Description
82000356	Rod End AHFT10 Stainless Steel
82000357	Rod End AHFT12 Stainless Steel

Rods ends can be purchased separately from draglink assemblies as spare parts.

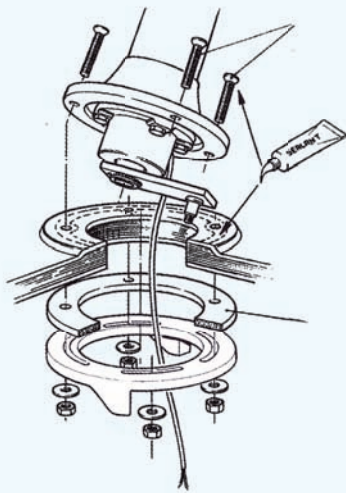
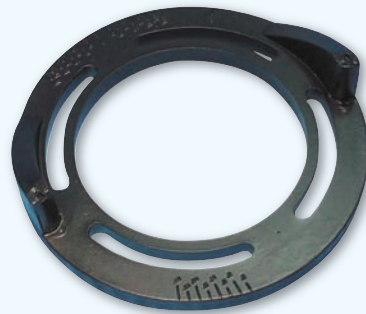

Illustration showing detail of Stop Ring. Custom Stop Ring also available.



89000004  
Stop Ring Cobra



## Tiller Lever

Can be machined to

Part Number	Bore Size		Description
	mm	in	
89500002	80	3	Tiller Lever
89500005	100	4	Tiller Lever
89500008	125	5	Tiller Lever

Lewmar also offers extended versions to enable the fitting of linear drive type autopilots at 250mm/10" and 50mm/14" centers, in conjunction with the standard 203mm/8" position for the steering draglink.

All above part numbers are for standard Tiller Levers supplied pilot bored. We offer a machining service to supply the Tiller Lever ready to suit the rudder stock of the boat. Please contact your Lewmar Distributor for part number and price prior to ordering assemblies as spare parts.



Draglink complete with rod end.

## Draglinks

Part Number	Description	Length one end loose		System Type
		mm	in	
89500011	Draglink Assemblies AHFT 10	1000	40	Cruising
89500012	Draglink Assemblies AHFT 10	2000	80	Cruising
89500013	Draglink Assemblies AHFT 12	1000	40	Racing and Ocean
89500014	Draglink Assemblies AHFT 12	2000	80	Racing and Ocean

The draglinks specified above are supplied with one end fitting loose to enable the tube to be cut to size and welded. If you know the correct centers for the draglink, contact your Lewmar dealer prior to order for the part number relating to the center required.

# Mamba™

The Mamba™ system provides the ultimate in marine steering, in terms of precision, feedback and strength. Mamba™ systems are chosen for a diverse range of sail and power craft such as blue water cruising yachts, pilot vessels and sail training vessels.

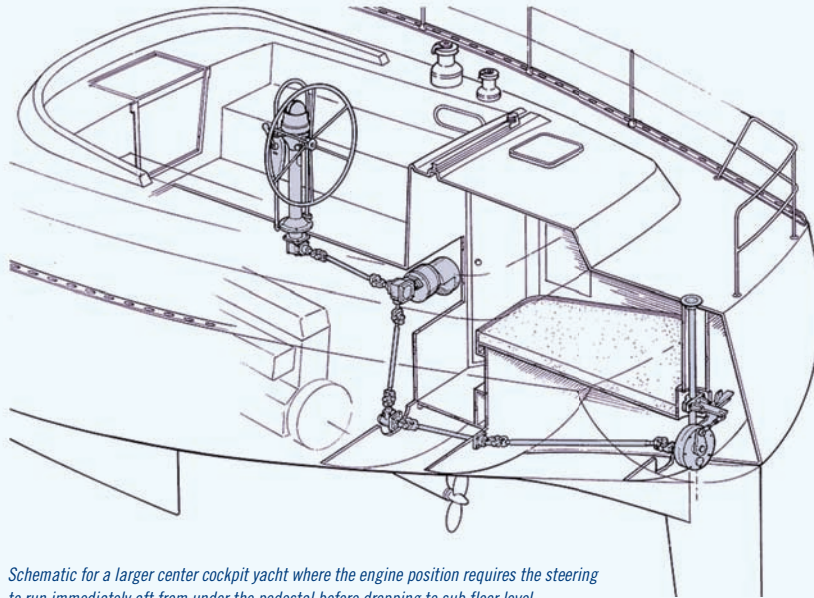

*Schematic for a larger center cockpit yacht where the engine position requires the steering to run immediately aft from under the pedestal before dropping to sub floor level.*

*Please note the autopilot drive attachment.*

## Features

- All parts are CNC machined, gearcut and assembled for the highest precision
- Bevelheads and gearboxes are manufactured using only marine grade materials
- Mamba™ offers enormous strength with minimal maintenance
- Maintained well, Mamba™ delivers a lifetime of service
- Reduction gearboxes accommodate rudder torques up to 5400mKg
- Instant rudder feedback
- Gearboxes and bevelheads provide high efficiency – fully reversible and totally positive



## Principle of Operation

Mamba™ steering is a rotating torque tube and bevelhead system, transmitting the helmsman's input to a high-efficiency reduction gearbox, mounted adjacent to the rudder stock. A tiller lever is fitted to the rudder stock and is driven by a similar lever integral to the gearbox, via a fully articulating jointed draglink.

Two or three station systems, catamarans and tandem wheel steering systems are regularly supplied. The integration of autopilot drives and remote controlled disengagement units are easily achieved.

The Mamba™ range of steering systems is offered in two sizes of transmission bevel boxes called BH10 and BH130, which are coupled with 12 models of reduction gearbox, providing equipment to suit all craft from 10.6m/35' to 61m/200'.

In most cases, either high-efficiency spur, or reduction gearboxes are chosen, offering between 1.0 and 26 turns lock to lock. Each option also provides a high reverse efficiency, transmitting rudder feel to the helmsman.

To simplify installations, Mamba™ equipment offers the following examples of versatility:

- Bevelheads can be supplied with 2, 3 or 4 steering shafts, permitting integration for secondary steering stations, tandem wheel arrangements and direct coupled autopilot drives.
- A choice of mounting plates and brackets for bevel and gearboxes.
- Availability of step ration gears to adjust overall steering ratio.

The lever geometry for Lewmar transmission systems is based on the principle of Wide Angle Geometry. Refer to p.210

# Mamba™ Typical Installations

Lewmar can accept a Naval Architect's designs in Autocad or DXF format as well as conventional drawings.

Here are some sample schematics showing the versatility of the Mamba system.

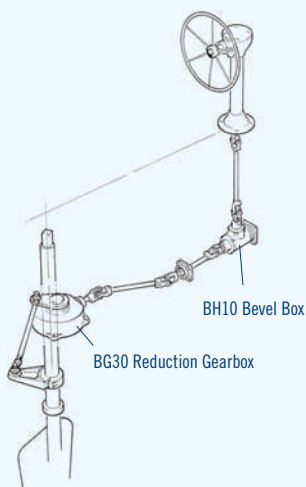
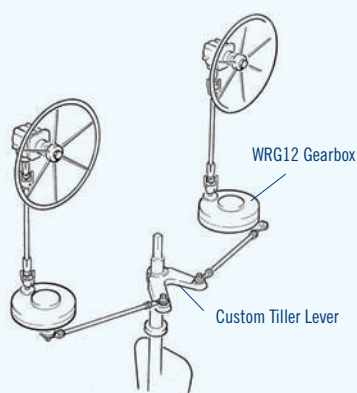

Tandem wheel arrangement operating through twin WRG series reduction gearboxes. This is a simple installation with minimum steering equipment and provides independent steering at each helm station.

In this arrangement a BG30 reduction gearbox is situated adjacent to the rudder stock. The gearbox is mounted parallel to the hull, which assists in keeping the torque tubes low in the boat.

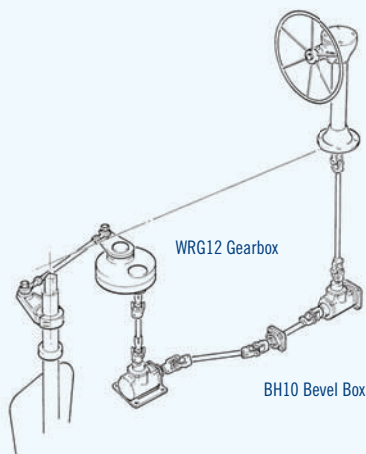
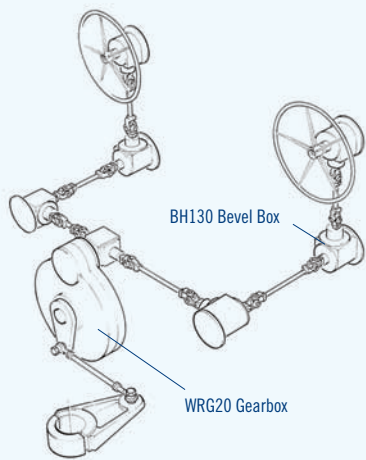
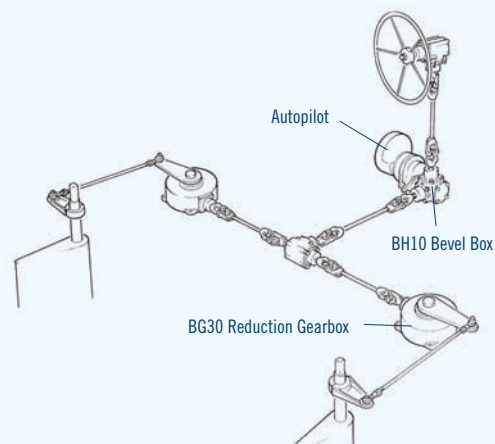

An alternative tandem wheel installation for the larger yacht.

Where the rudder stock and bearing are mounted higher in the boat, this arrangement is preferable.

An illustration showing a typical Mamba™ installation for a catamaran. The rigidity and backlash-free nature of the Mamba™ system means that it is unnecessary to have a draglink between the rudders to achieve synchronization.

In addition, Lewmar can arrange the geometry to provide the Ackerman effect, which increases the turn angle on the inside rudder to improve steering reaction.

This example also illustrates the simple connection of the Lewmar autopilot drive.

# Mamba™ Bevelheads

## BH10

Lewmar BH10 torque tubes are made of marine grade stainless steel depending on the specific installation requirements. Torque tubes are supplied in standard lengths with one end loose for welding by the installer. Or we offer fully welded torque tubes to pre-specified lengths.

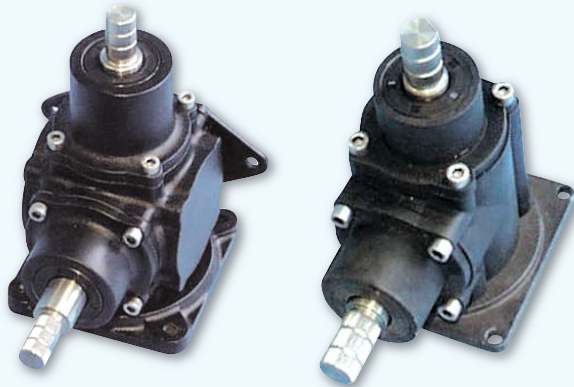

Bevelheads

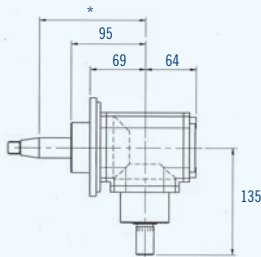

Steering Bevelhead (BH10)

\* To suit customer requirements

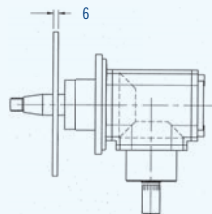

Steering Bevelhead with Brake (BH10)

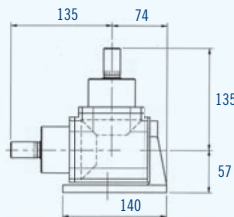

Transfer Bevelhead (BH10)

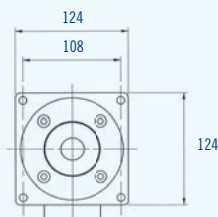

Steering Bevelhead (BH10 Front View)

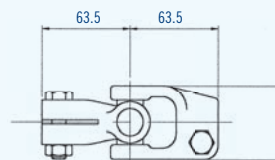

89200057

AMK10 Universal Joint



Mamba Universal Joint and Self-Aligning Bearing

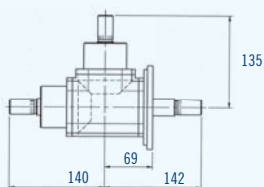

Transfer Bevelhead 3-way (BH10)

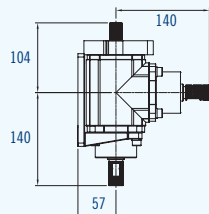

3-way Bevelbox with AP Flange (BH10)

## Useful information

- 1 Steering shafts can be made to customer's preferred length.
- 2 Bevelheads are available with either rotation.
- 3 Standard bevelheads have 1:1 ratio, but other ratios are available as detailed in specification.
- 4 Mounting plate (or bracket) can be fitted to all faces to facilitate ease of mounting.
- 5 All bevelheads can be configured to accept the Lewmar direct fit autopilot mount.
- 6 For detailed dimensions refer to Lewmar CAD library.
- 7 Due to the custom nature of this product, contact Lewmar for part number.

## Features

- Manufactured from marine grade aluminum castings
- Precision machined and chromed
- Stainless Steel shaft work coupled with high alloy steel or Nickel ali bronze bevel gears
- Shaft work runs in high-efficiency roller bearings with oil seals and fully greased housings
- Bevelheads are shimmed for zero backlash
- All components are fully bedded in, prior to supply

## Universal Joints

Must be fitted at both ends of a torque tube. Where a self-aligning bearing is used, one universal joint connects both torque tubes, as shown in illustrations. Self-aligning bearings work up to an angle of 15°. AMK10 universal joints have a maximum permissible working angle of 25°. Where practical, the angle at each joint should be balanced.



# Mamba™ Bevelheads

## BH130

Lewmar BH130 torque tubes are made of marine grade stainless steel. Depending on the specific installation requirements, torque tubes are supplied in standard lengths with one end loose for welding by the installer. Or, we offer fully welded torque tubes to pre-specified lengths.



**Bevelheads**

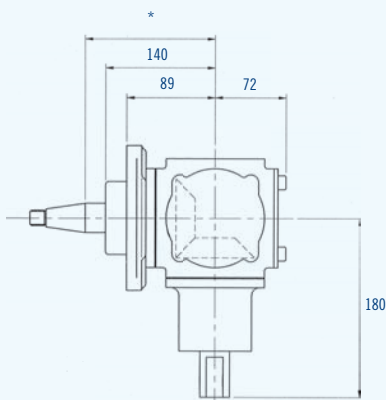

**Steering Bevelhead (BH130)**

\* To suit customer requirements

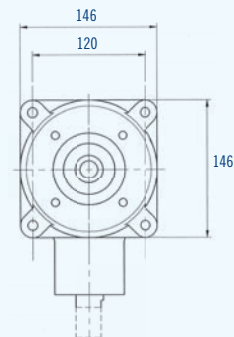

**Steering Bevelhead (BH130 Front View)**

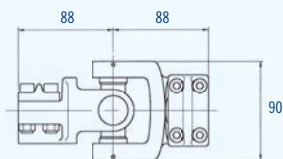

**89200070**

WUJ6 Universal Joint

The WUJ6 universal joint is suitable for use with large gearboxes 18, 20 and 45, see page 220. It has a maximum permissible working angle of 25°. Where practical, the angle at each joint should be balanced.

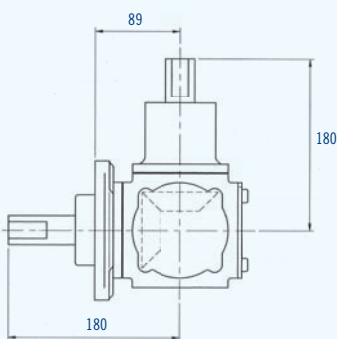

**Transfer Bevelhead (BH130)**

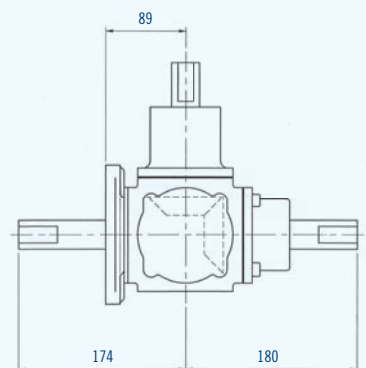

**Transfer Bevelhead with Autopilot Adaptor Flange 3-way (BH130)**



# Mamba™ BG Reduction Gearboxes

The BG Series of high-efficiency reduction gearboxes employs bevel gears manufactured from either high-alloy steel or nickel bronze alloy running in precision roller bearings. Gear casings are manufactured from marine grade aluminum, and shaft work is stainless steel or nickel bronze alloy. All gearboxes are grease filled and shimmed for zero backlash.

## Mamba™ Reduction Gearboxes

Part Number	Gearbox Type	Gear Ratio	Mechanical Advantage at Midships	Turns Ho to Ho	Maximum Rudder Torque		Typical Boat Range
					Nm	ft-lbs	
89200034	BG12	5:1	8.1	1.8	2,943	2,170	-45'
89200035	BG12/2	5:1	8.1	1.8	2,943	2,170	-45'
89200040	BG30	6.7:1	10.2:1	2.4	4,905	3,617	45'–60'

### Notes

- 1 Mechanical advantage and turns lock to lock are based on standard level geometry.
- 2 Reduction gearboxes can be mounted anywhere within the general proximity of the rudder stock (7"/0.2m to 6.5'/2m).
- 3 For detailed dimensions refer to Lewmar CAD library.



**89200034**  
Gearbox (BG12)

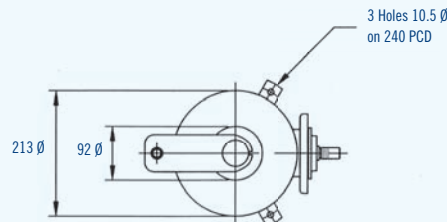
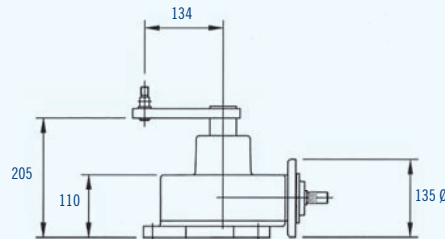

**89200034**  
Gearbox (BG12)

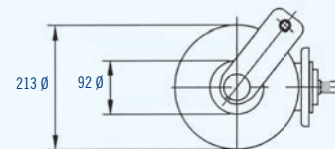
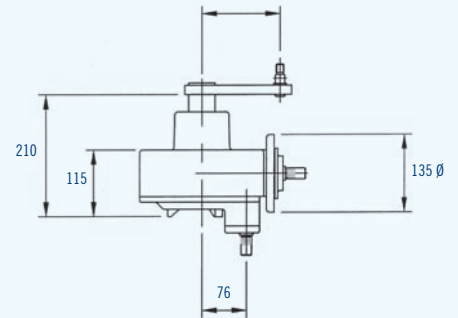

**89200035**  
Gearbox with second output for autopilot drive or additional steering position (BG12/2)

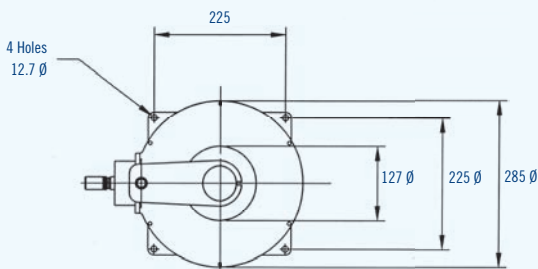
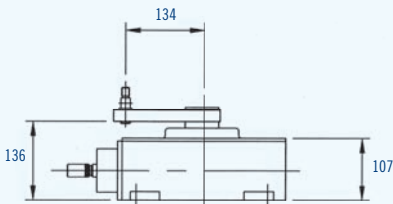

**89200040**  
Gearbox (BG30)



# Mamba™ WRG Reduction Gearboxes

The WRG series of high-efficiency gearboxes employs precision cut, stub tooth form, spur gears running in deep groove ball and roller bearings. Gear casings are manufactured from marine grade aluminum, and shaft work is in stainless steel or nickel ali bronze. All gearboxes are CNC Machined and grease filled to ensure a perfect fit and maintenance free life.

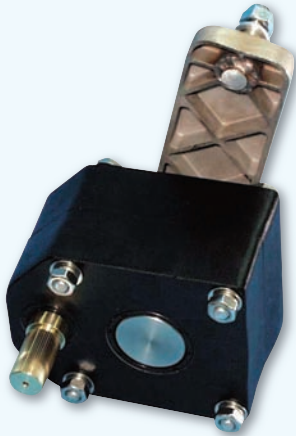

**89200032**  
Gearbox (WRG10)



**89200041**  
Gearbox (WRG12)



**89200046**  
Gearbox (WRG18)

## Mamba™ Reduction Gearboxes

Part Number	Gearbox Type	Gear Ratio	Mechanical Advantage at Midships	Turns Ho to Ho	Maximum Rudder Torque		Typical Boat Range	
					Nm	ft. lbs	m	ft
89200032	WRG10	4:1	6.1:1	1.4	2,452	1,808	-13	-45
89200037	WRG11	5:1	8:1	1.8	2,943	2,170	11.5-14	38-45
89200041	WRG12	7:1	10.8:1	2.45	5,150	3,798	13-20	45-65
89200046	WRG18	10:1	15.2:1	3.5	10,800	7,965	18-27	60-90
89200048	WRG20	12.6:1	19.1:1	4.4	13,700	10,104	24-33.5	80-110
89200050	WRG45	13:1	20:1	4.6	24,000	17,701	20-46	90-120
89201637	WRG60	24.7:1	37.5:1	8.6	36,250	26,740	33-45	110-150
89200052	WRG90	65:1	96:1	21.6	53,000	39,090	36.5-61	120-200

### Notes

- Mechanical advantages and turns lock to lock are based on standard lever geometry.
- Overall mechanical advantage and turns lock to lock can be altered via stepped ratio bevels in bevelheads within the system or by non-standard lever centers.
- Reduction gearboxes can be mounted anywhere within the general proximity of the rudder stock (0.2m/7" to 2m/6.5'). For more details please refer to the installation and maintenance handbook.
- Bevelheads can be directly integrated to all WRG series gearboxes.
- For detailed dimensions, refer to Lewmar CAD library.

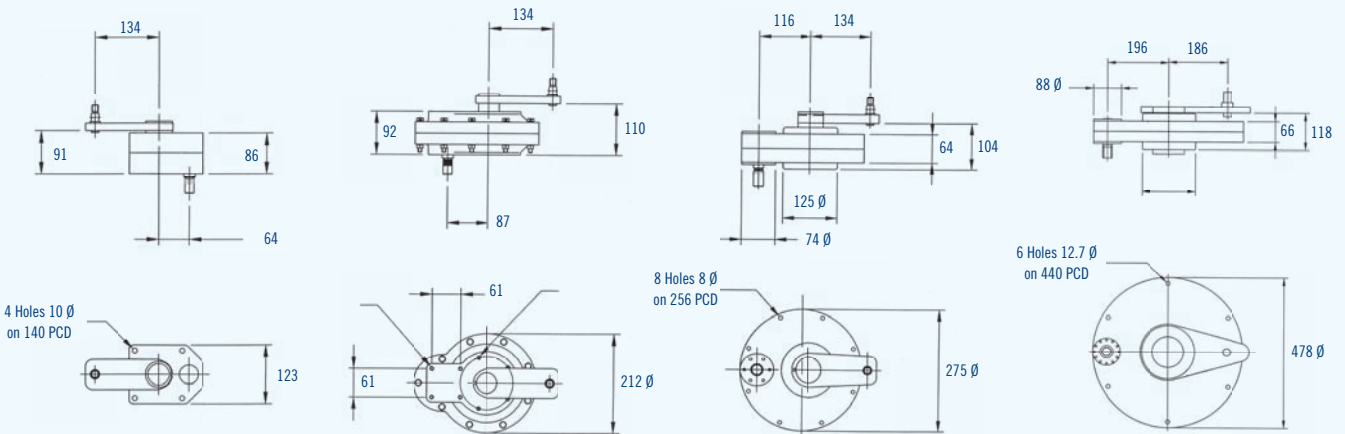

**89200032**  
Gearbox (WRG10)

**89200037**  
Gearbox (WRG11)

**89200041**  
Gearbox (WRG12)

**89200046**  
Gearbox (WRG18)



# Mamba™ WRG Reduction Gearboxes (continued)

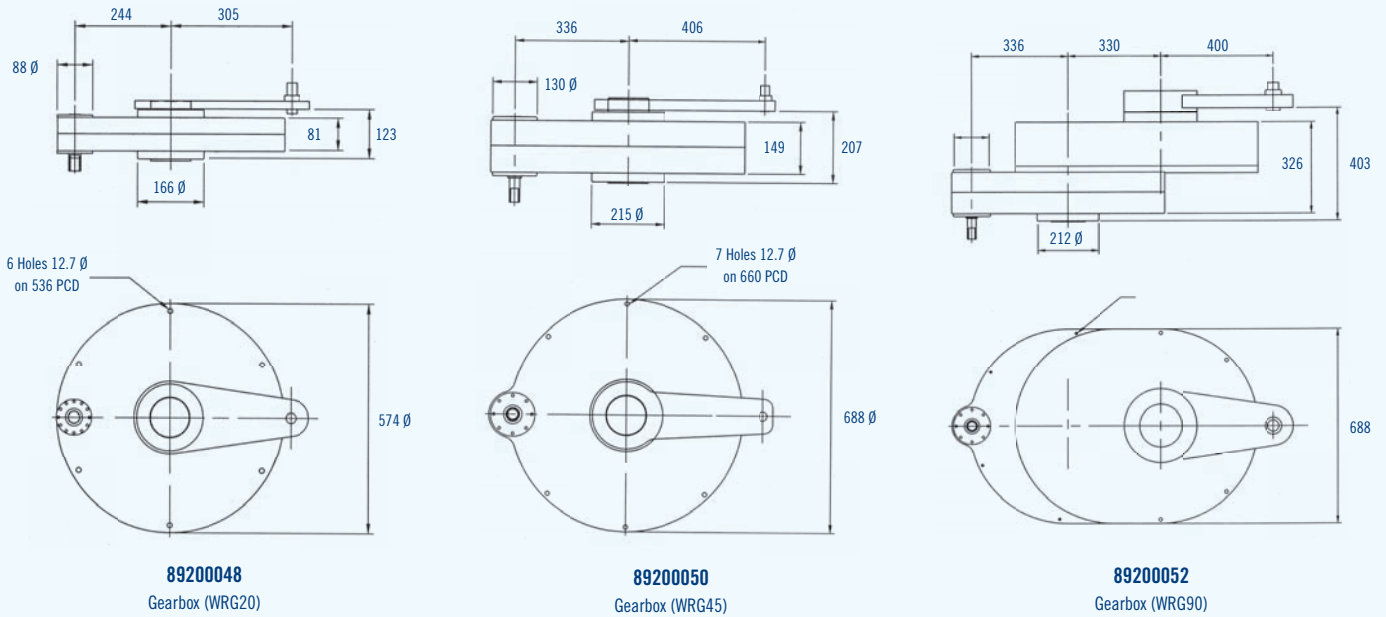

## Mamba™ Bevelhead Integration

Integration – WRG series of spur reduction gearboxes can be supplied with an integral bevelhead fitted to the input shaft as per illustrations below. The bevelhead can be mounted to either side of the reduction gearbox and rotated at any angle. Custom arrangements are available with great stand-offs between the gearbox and bevelhead. Lewmar provides an in-house design service for Mamba installations.

### Pedestal Gearbox Integration

Mamba™ pedestal – BG WRG Integration – For larger aft cockpit yachts, the WRG and BG series gearboxes can be directly mounted to the pedestal.

On the WRG12 gearbox and above – a torque adapter plate is provided to transmit the force directly to the underside of the cockpit floor.

For raked rudders (25° and above), it is normal to use the BG series of gearboxes, see page 219.

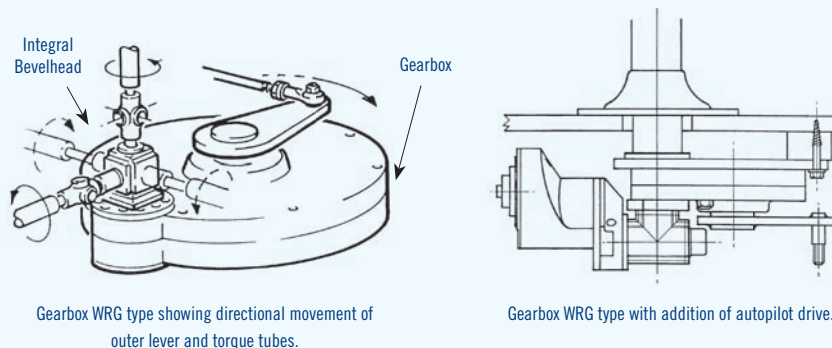

## Mamba™ Custom & Power Assistance

The use of hydraulic power assistance superimposed on mechanical rack and pinion steering is now universally used on motor vehicles around the world. A well-designed system enables a much more direct steering to be employed while retaining the essential feel provided by a proportional valve integral within the system.

Lewmar offers a similar arrangement for use in marine steering applications. Utilizing hydraulic power, either from a power take-off from the engine, or its own power pack with integral reservoir, the Lewmar proportional servo valve fits in line with the draglink and directs oil flow to assist the helmsman's efforts.

The amount of power assistance can be varied to suit each owner's taste and can provide everything from a fingertip response to conventional steering loads, but at reduced levels.

In all cases however, the integrity of the mechanical steering is retained and should the power assistance be switched off, or fail, a high flow bypass valve will allow the oil to flow freely, and normal mechanical operation to continue.

Lewmar power assisted Mamba systems are used on a wide variety of craft, varying from large sailing yachts to commercial vessels, all benefiting from quicker, lighter response, coupled with unimpeded feel and accuracy.



# Autopilot Drives

Our experience has given us insight into the challenges that can occur when interfacing autopilot drives to the steering system and how important this aspect is to the correct operation of the autopilot. Our comprehensive range of mechanical and hydraulic autopilot drive units helps overcome typical installation problems.

1. All units have an electromechanical clutch, virtually eliminating drag on the steering system.
2. All units are compatible with the majority of electronics suppliers, such as Raymarine, B&G and Simrad.
3. All drives have low current draw.
4. Drives available in 1/4, 1/2 and 1HP capacities, suitable for all Lewmar steering types.



Lewmar recommends the following Drive Units for your boat. If your boat is not listed here, please contact Lewmar for further information.

Boat Builder/ Boat Model	Drive Type	Part Number
<b>Bavaria</b>		
30, 33, 37, 39 cruisers	Integra	<b>89300111</b>
Match 35, 38, 42	Direct	<b>89300100</b>
42, 44, 46, 49, 50 cruisers	Mamba	<b>89300053</b>
<b>Dufour</b>		
34	Constellation	<b>89300109</b>
40, 44	Constellation	<b>89300086</b>
385, 455	Constellation	<b>89300123</b>
Gib Sea 43	Mamba	<b>89300053</b>
365, 385, 445	Rotary	<b>89100160+</b> <b>89300003</b>
<b>Halberg Rassy</b>		
40, 43	Mamba	<b>89300051</b>
46, 48, 53 - 12v	Mamba	<b>89300053</b>
46, 48, 53 - 24v	Mamba	<b>89300054</b>
62	Mamba	<b>89300060</b>
<b>Hanse</b>		
341, 371, 411	Direct	<b>89300039+</b> <b>89500497</b>
461	Mamba	<b>89300053</b>
531	Mamba	<b>89300057</b>
<b>Hunter</b>		
44, 49	Mamba	<b>89300053</b>
45CC	Integra	<b>89300113</b>

Boat Builder/ Boat Model	Drive Type	Part Number
<b>Island Packet</b>		
370	Direct	<b>89300040</b>
440	Direct	<b>89300040</b>
445	Mamba	<b>89300053</b>
485	Mamba	<b>89300053</b>
<b>Najad</b>		
400	Mamba	<b>89300051</b>
460, 490, 511	Mamba	<b>89300053</b>
<b>Northshore</b>		
Southerly 110	Direct	<b>89300103+</b> <b>89300099</b>
Southerly 32	Integra	<b>89300104</b>
Southerly 35RS	Direct	<b>89300103+</b> <b>89300100</b>
Southerly 135	Mamba	<b>89300053</b>
Southerly 115	Mamba	<b>89300053</b>
Vancouver 34, 38	Mamba	<b>89300053</b>
<b>Oyster</b>		
62, 655	Mamba	<b>89300060</b>
72, 82	Mamba	<b>89300070</b>
<b>Tartan</b>		
3400	Direct	<b>89300039</b>
3700	Direct	<b>89300039</b>
4100	Direct	<b>89300039</b>
4400	Direct	<b>89300039</b>

Autopilot drive manuals and installation guides can be found on the Lewmar website [www.lewmar.com](http://www.lewmar.com).

# Integra Drives

The Integra drive is available in three formats.

The Cobra and Mamba versions mount directly inside the Integra pedestal. This unique installation is only available from Lewmar and provides the installer with a simple and quick installation with no complicated, labor intensive mounting platforms required.

We also offer an Integra Sprocket version, which is very popular with the Bavaria Cruising yachts from 9 to 12m (30 to 39ft) in length.



Part Number	Description
89300111	Bavaria Integra drive
89300104	12V* Integra Cobra drive
89300113	12V* Integra Mamba drive

\* Voltage relates to clutch

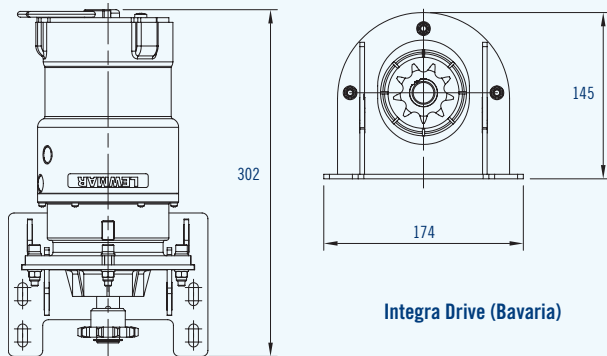

Integra Drive (Bavaria)

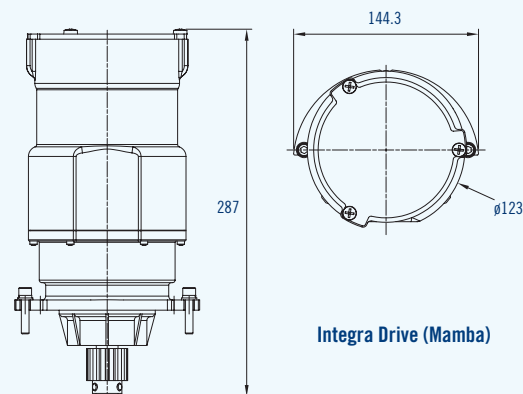

Integra Drive (Mamba)

## Custom Low Profile Integra Pedestal

Showing access panel opened for Integra Autopilot installation.

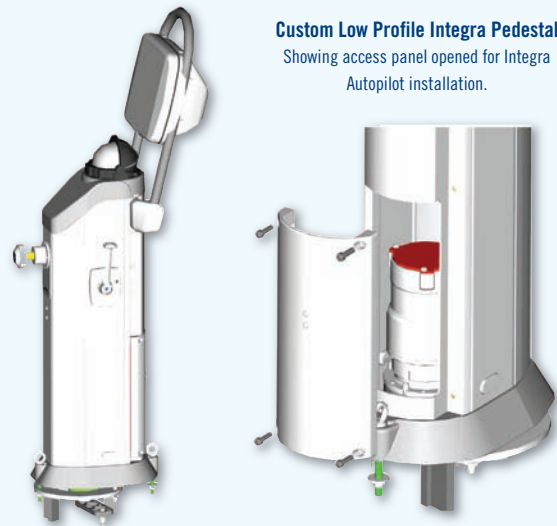

# Constellation™ Drives

The Constellation™ Autopilot Drive units are specially designed to interface with Constellation™ Steering, incorporating wire-in-conduit transmission, typically found in center cockpit yachts up to 21m/70'.



## Features

- Direct mounting under pedestal for minimal space
- Easy and quick to install
- Flexible – suitable for most deck thicknesses
- Strong and reliable
- 1/4 HP and 1/2 HP version available
- 12 and 24 volt options

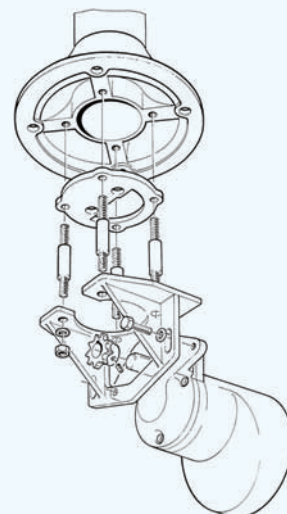

## Constellation™ Drive Unit Specifications

Part Number	Sprocket Size	HP	*Voltage	Max Output Torque		No Load Speed RPM	Max Rudder Torque		Average Current Consumption	Weight	
				Nm	ft-lb		mKg	ft-lb		kg	lb
89300016	5/8" P Sprocket Standard	1/4	12	169	125	10	248	1794	4A	9	19.8
89300017	5/8" P Sprocket Standard	1/4	24	169	125	10	248	1794	2.5A	9	19.8
89300029	5/8" P Sprocket Standard	1/2	24	183	135	10	426	3080	3.5A	10.5	23.1

\* Voltage relates to clutch

# Mamba™ Drives

These unique autopilot drives directly couple to Mamba™ systems, eliminating the need for separate mounting platforms, chain and sprockets.



The illustration (below) shows the simplicity of installation of the Mamba™ drive unit fitted to a BH10 type bevelhead via the interface plate. The drive is transmitted via a splined muff-to-shaft connection.

The bevelhead or gearbox provides the mounting, and no additional support is necessary for the autopilot drive unit.

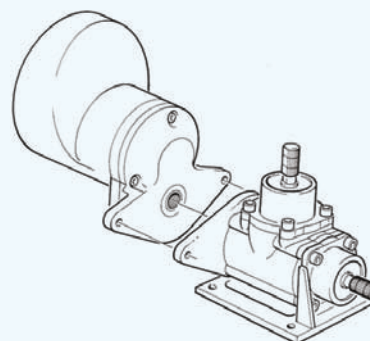

## Mamba™ Drive Unit Specifications

Part Number	Spine Coupling Connection	HP	*Voltage	Max Output Torque		No Load Speed RPM	Max Rudder Torque		Average Current Consumption	Weight	
				Nm	ft-lb		mKg	ft-lb		kg	lb
89300053	3/4 x 48	1/4	12	169	125	10	248	1794	4A	9	19.8
89300054	3/4 x 48	1/4	24	169	125	10	248	1794	2.5A	9	19.8
89300055	3/4 x 48	1/4	24	169	125	10	248	1794	2.5A	9	19.8
89300060	3/4 x 48	1/2	24	183	135	13	426	3080	3.5A	10.5	23.1
89300061	3/4 x 48	1/2	24	183	135	13	426	3080	3.5A	10.5	23.1

\* Voltage relates to clutch.



# Direct Drives



Direct Drive

## Features

- Available in Constellation™, Cobra™ and Mamba™ steering systems
- Extremely powerful, delivering up to 2432Nm/1794ft-lb of torque
- Virtually zero drag – steering performance is not impaired
- Compact Direct Drive, enabling close mounting to the rudder stock, at any attitude

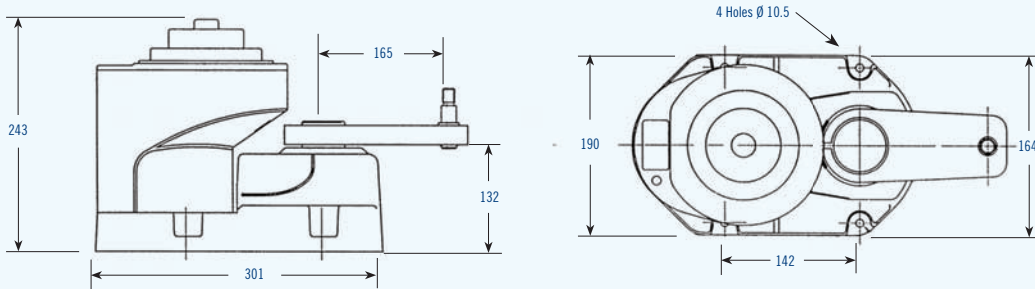

Direct Drive

Uniquely, the Direct Drive can operate onto the pedestal or gearbox output lever as an alternative to the rudder lever. This offers the installer and boat designer more options for layout as the Direct Drive can be mounted in any attitude.

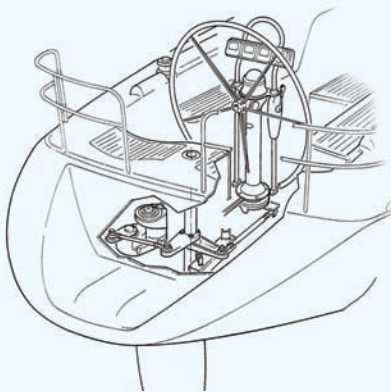

The illustration (left) shows a typical aft cockpit steering (Cobra™) with a Direct Drive installation mounted alongside the rudder stock. Due to its design, Direct Drive can be mounted far closer to the rudder stock than any other linear drive arrangement. Minimum center distance for the draglink connecting the Direct Drive to the rudder lever is 100mm/4".

89500035

Direct Drive connected to a Tiller lever via draglink.

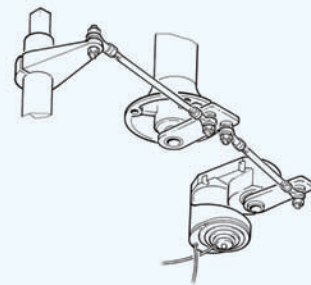

## Direct Drive Unit Specifications

Part Number	Output Lever Center	HP	*Voltage	No Load Speed		Max Rudder Torque		Average Current Consumption	Weight	
				Ho-Ho		mKg	ft-lb		kg	lb
89300039	166mm lever	1/4	12	10s	248	1794	4A	8.8	19.4	
89300041	166mm lever	1/4	24	10s	248	1794	4A	8.8	19.4	
89300045	166mm lever	1/2	24	12s	345	2496	3.5A	24.8	55	
89300049	166mm lever	1/2	24	17s	493	3566	3.5A	45.5	100	

\* Voltage relates to clutch.



# Rotary Sprocket Drives to suit Constellation™ and Mamba™



Lewmar offers three sizes of powerful and compact rotary drive units, which employ conventional chain and sprocket connection to the steering system. The high-efficiency, twin stage, epicyclic gearbox is grease filled, which allows mounting in any attitude. And the wide mounting platform is slotted to aid chain tensioning.

Rotary drives are generally used on cable and push-pull steering systems and it is necessary to calculate the correct driven sprocket, which is dependent on the turns (mechanical advantage) of the steering system. Lewmar can supply fully machined sprockets for your steering system in steel or stainless steel upon request, as well as chain and master links.

Please refer to the graph to calculate the correct sprocket size. The turns lock to lock is referred to at the position on the steering where the driven sprocket is to be mounted.

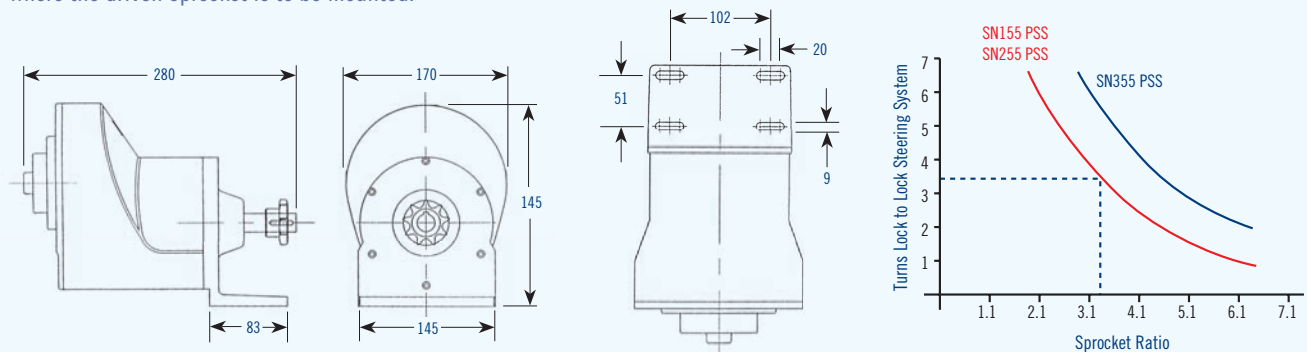

## Rotary Sprocket Drive Unit Specification

Part Number	Sprocket Size	Type	HP	*Voltage	Max Output Torque		No Load Speed RPM	Max Rudder Torque		Avg Current Consumption	Weight	
					Nm	ft-lb		mKg	ft-lb		kg	lb
89300000	5/8" P 9T Sprocket	SN155PSS	1/8	12	24	18	44	116	840	2A	7.8	17.2
89300002	5/8" P 9T Sprocket	SN255PSS	1/4	12	43	32	44	207	1500	4A	8.8	19.4
89300004	5/8" P 9T Sprocket	SN255PSS	1/4	24	43	32	44	207	1500	2.5A	8.8	19.4
89300008	5/8" P 9T Sprocket	SN355PSS	1/2	24	47	35	55	332	2400	3.5A	10	22
89300010	5/8" P 9T Sprocket	SN455PSS	1	24	466	344	18	1660	12055	6A	30	66.1

\* Voltage relates to clutch.

## Mamba™ Sprocket 1HP Drives

Lewmar has developed a 1HP Drive Unit motor suitable for sailing yachts and commercial vessels up to 60m/ 200'.

With the capacity to steer such vessels on a continuous rating basis, utilizing a 1HP twin rotor, ultra high-efficiency printed circuit motor, the unit offers the major advantage of variable speed operation, ensuring far higher steering accuracy and less strain on the steering mechanism and rudder linkage.

The 1HP Twin Rota is compatible with a number of autopilot manufacturers' electronics.

This particular unit typically consumes less than 1/5 of the power consumption of a similarly rated hydraulic power pack. The 1HP Drive has an output rating of 248Nm and a maximum output torque of 468Nm.



## Mamba™ 1HP Drive Unit Specification

Part Number	Type	HP	*Voltage	Max Output Torque		No Load Speed RPM	Max Rudder Torque		Avg Current Consumption	Weight	
				Nm	ft-lb		mKg	ft-lb		kg	lb
89300064	SN455PSM	1	24	466	344	18	1,660	12,055	6A	30	66.1



# Rudder Bearings and Stocks

Lewmar offers a range of rudder bearings and rudder stocks to complement yacht steering systems. Lewmar's rudder bearings come in two basic types – plain roller and self-aligning roller. We can provide a rudder bearing solution for any yacht, whether it's tiller steered or a Grand Prix racer. Lewmar roller bearings are designed for production yachts as well as custom one-off yachts. Choose from our range or speak to your Lewmar representative for a specification and design to suit your rudder bearing requirements.

## Tiller Steered Yachts – Rudder Bearing Solutions

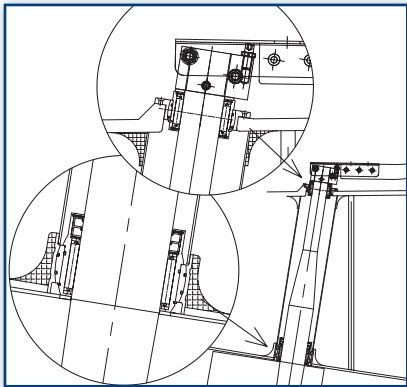

This tiller steered boat is using self-aligning roller bearings that simplify installation and allow for any bending movement in the rudder shaft when under sailing conditions. A rudder tube is slotted into the lower self-aligning bearing, which extends the lower bearing outer housing up to the upper bearing.

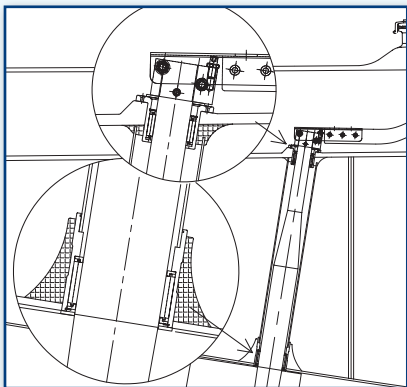

This is a typical example of a production boat using a tiller rudder bearing installation. The lower bearing is quick and simple to install, and there is no laminating or bonding of the bearing to the hull required. When using a conical lower bearing the builder will laminate the hull and the housing, for the bearing is formed using a mold tool. To install, the bearing sealant is applied to the outer surface and then positioned and the nut tightened to hold in position.

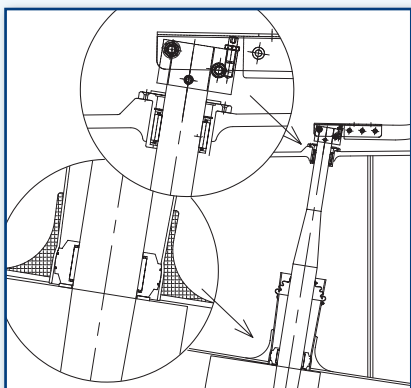

Here is an example of a tiller steered rudder system for a one-off or low volume sailing boat. When aligning the bearings, the rudder shaft must be positioned and the plain roller rudder bearings are either bonded or laminated to the vessel hull and deck.





# Rudder Bearings and Stocks (continued)

## Wheel Steered Yachts – Rudder Bearing Solutions

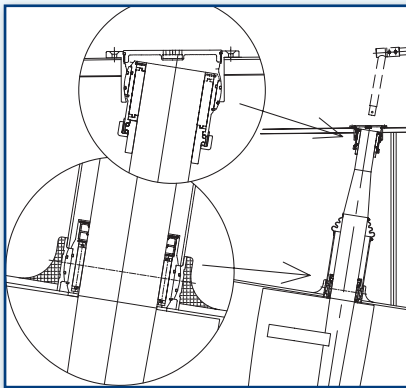

This wheel steered boat is using self-aligning roller bearings that simplify installation and allow for any bending movement in the rudder shaft when under sailing conditions. A rudder tube is slotted into the lower self-aligning bearing, which extends the lower bearing outer housing up to the upper bearing.

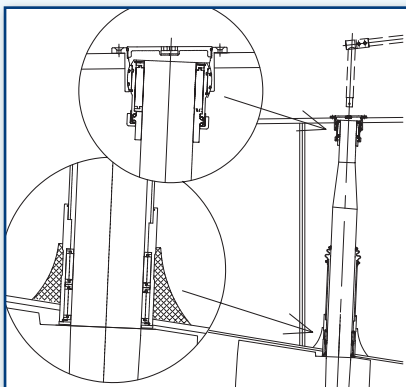

This is a typical example of a production wheel steered boat using a rudder bearing installation. The lower bearing is quick and simple to install, and there is no laminating or bonding of the bearing to the hull required. When using a conical lower bearing, the builder will laminate the hull and the housing, for the bearing is formed using a mold tool inset within the hull mould tool. To install, the bearing sealant is applied to the outer surface and then positioned and the nut tightened to hold in position.

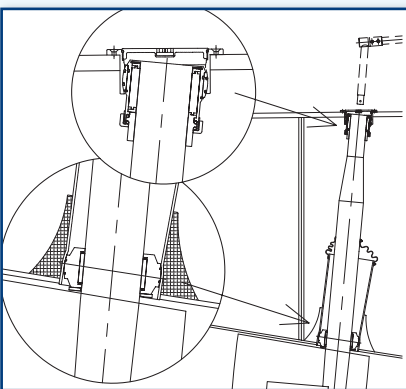

Many production boat builders like this type of solution as it allows for increased angles of the rudder shaft to the hull. The rudder bearing housing is GRP and allows for an easy laminating process to the hull. Sealing the bearing is completed with a gaiter, and these are easily replaced with the requirements to remove the rudder from the boat.



# Rudder Bearings and Stocks (continued)

## Specification Guidelines

	Vessel Type			Sealing system	
	Tiller Boats	Cruising Yachts	Racing Yachts	Lip Seals	Tube & Gaitor
Tiller Head Fittings	•				
Upper Roller Bearings	•	•			
Upper Bearing with deck cover and thrust race		•			
Upper Self-aligning Roller Bearings		•	•		
Upper Self-aligning Roller Brgs with thrust race			•		
Lower Roller Bearings Alloy	•	•		•	•
Lower Self-aligning Roller Bearings Alloy		•	•	•	•
Lower Self-aligning Roller Bearing GRP		•	•		•

## Tiller Heads

- Tiller head block manufactured in 6082 alloy and anodized
- Suit shaft diameters 25mm–50mm
- Height and angle adjusted by set screws
- ‘U’ shape channel manufactured in 316 stainless steel

Part Number	Rudder Stock Diameter	
	mm	in
89601000	25	1
89601001	30	1 3/16
89601002	35	1 3/8
89601003	40	1 9/16
89601004	45	1 3/4
89601005	50	1 15/16



## Plain Roller Upper Bearing

- Manufactured in 6082 aluminum and anodized
- Suit rudder stock diameters 35mm–109mm
- Precision Delrin rollers
- Low friction co-efficient
- Easy-to-install flanged housing
- Custom sizes available

Part Number	Rudder Stock Dia		Max Work Load	
	mm	in	kg	lb
89600170-89600179	50 - 59	1 15/16 - 2 5/16	3000	6614
89600180-89600189	60 - 69	2 3/8 - 2 11/16	3500	7716
89600190-89600199	70 - 79	2 3/4 - 3 1/8	4000	8818
89600200-89600209	80 - 89	3 1/8 - 3 1/2	4500	9921
89600210-89600219	90 - 99	3 9/16 - 3 7/8	5000	11023
89600220-89600229	100 - 109	3 15/16 - 4 5/16	5500	12125



## Plain Roller Upper Bearing with Deck Cover and Thrust Race

- Manufactured in 6082 aluminum and anodized
- Suit rudder stock diameters 50mm–109mm
- Integral locking ring
- Easy-to-install flanged housing
- Integral deck cover
- Custom sizes available

Part Number	Rudder Stock Dia		Max Work Load	
	mm	in	kg	lb
89600110-89600119	50 - 59	1 15/16 - 2 5/16	3000	6614
89600120-89600129	60 - 69	2 3/8 - 2 11/16	3500	7716
89600130-89600139	70 - 79	2 3/4 - 3 1/8	4000	8818
89600140-89600149	80 - 89	3 1/8 - 3 1/2	4500	9921
89600150-89600159	90 - 99	3 9/16 - 3 7/8	5000	11023
89600160-89600169	100 - 109	3 15/16 - 4 5/16	5500	12125



# Rudder Bearings and Stocks (continued)

## Upper Self-aligning Roller Bearings

- Manufactured in 6082 aluminum and anodized
- Suit rudder stock diameters 50mm–120mm
- Bearing includes self-aligning ball and precision Delrin rollers
- Easy-to-install flanged housing
- No grease or maintenance required

Part Number	Rudder Stock Diameter	
	mm	in
89601006-89601015	50 - 59	1 <sup>15</sup> / <sub>16</sub> - 2 <sup>5</sup> / <sub>16</sub>
89601016-89601025	60 - 69	2 <sup>3</sup> / <sub>8</sub> - 2 <sup>11</sup> / <sub>16</sub>
89601026-89601035	70 - 79	2 <sup>3</sup> / <sub>4</sub> - 3 <sup>1</sup> / <sub>8</sub>
89601036-89601045	80 - 89	3 <sup>1</sup> / <sub>8</sub> - 3 <sup>1</sup> / <sub>2</sub>
89601046-89601055	90 - 99	3 <sup>9</sup> / <sub>16</sub> - 3 <sup>7</sup> / <sub>8</sub>
89600156-89600165	100 - 109	3 <sup>15</sup> / <sub>16</sub> - 4 <sup>5</sup> / <sub>16</sub>
89600166-89600175	110 - 119	4 <sup>5</sup> / <sub>16</sub> - 4 <sup>11</sup> / <sub>16</sub>
89600176	120	4 <sup>3</sup> / <sub>4</sub>



## Upper Self-aligning Roller Bearings with Deck Flange and Vertical Thrust Race

- Manufactured in 6082 aluminum and anodized
- Suit rudder stock diameters 50mm–165mm
- Bearing includes self-aligning ball and precision Delrin rollers
- Easy-to-install flanged housing
- Integra Locking ring and vertical thrust race

Part Number	Rudder Stock Diameter	
	mm	in
89600380	50	1 <sup>15</sup> / <sub>16</sub>
89600381	60	2 <sup>3</sup> / <sub>8</sub>
89600382	70	2 <sup>3</sup> / <sub>4</sub>
89600383	80	3 <sup>1</sup> / <sub>8</sub>
89600384	100	3 <sup>15</sup> / <sub>16</sub>
89600385	115	4 <sup>1</sup> / <sub>2</sub>
89600386	120	4 <sup>3</sup> / <sub>4</sub>
89600387	140	5 <sup>1</sup> / <sub>2</sub>
89600388	150	5 <sup>7</sup> / <sub>8</sub>
89600389	165	6 <sup>1</sup> / <sub>2</sub>



## Lower Aluminum Roller Bearings

- Manufactured in 6082 aluminum and anodized
- Suit rudder stock diameters 50mm–109mm
- Accepts sealing system for lip seals or rudder tube and gaitor
- Low friction co-efficient
- No grease or maintenance required

Part Number	Rudder Stock Dia		Max Work Load	
	mm	in	kg	lb
89600040-89600049	50 - 59	1 <sup>15</sup> / <sub>16</sub> - 2 <sup>5</sup> / <sub>16</sub>	3000	6614
89600050-89600059	60 - 69	2 <sup>3</sup> / <sub>8</sub> - 2 <sup>11</sup> / <sub>16</sub>	3500	7716
89600060-89600069	70 - 79	2 <sup>3</sup> / <sub>4</sub> - 3 <sup>1</sup> / <sub>8</sub>	4000	8818
89600070-89600079	80 - 89	3 <sup>1</sup> / <sub>8</sub> - 3 <sup>1</sup> / <sub>2</sub>	4500	9921
89600080-89600089	90 - 99	3 <sup>9</sup> / <sub>16</sub> - 3 <sup>7</sup> / <sub>8</sub>	5000	11023
89600090-89600099	100 - 109	3 <sup>15</sup> / <sub>16</sub> - 4 <sup>5</sup> / <sub>16</sub>	5500	12125
89600100-89600109	110 - 119	4 <sup>5</sup> / <sub>16</sub> - 4 <sup>11</sup> / <sub>16</sub>	6000	13228



# Rudder Bearings and Stocks (continued)

## Lower Self-aligning Aluminum Roller Bearings

- Manufactured in 6082 aluminum and anodized
- Suit rudder stock diameters 40mm–140mm
- Bearing includes self-aligning ball and precision Delrin rollers
- Accepts sealing system for lip seals or rudder tube and gaitor
- No grease or maintenance required

Part Number	Rudder Stock Diameter	
	mm	in
89600453-89600462	40 - 49	
89600463-89600472	50 - 59	1 <sup>15</sup> / <sub>16</sub> - 2 <sup>3</sup> / <sub>16</sub>
89600473-89600482	60 - 69	2 <sup>3</sup> / <sub>8</sub> - 2 <sup>11</sup> / <sub>16</sub>
89600483-89600492	70 - 79	2 <sup>3</sup> / <sub>4</sub> - 3 <sup>1</sup> / <sub>8</sub>
89600493-89600502	80 - 89	3 <sup>1</sup> / <sub>8</sub> - 3 <sup>1</sup> / <sub>2</sub>
89600503-89600512	90 - 99	3 <sup>9</sup> / <sub>16</sub> - 3 <sup>7</sup> / <sub>8</sub>
89600513-89600522	100 - 109	3 <sup>15</sup> / <sub>16</sub> - 4 <sup>5</sup> / <sub>16</sub>
89600523-89600532	110 - 119	4 <sup>5</sup> / <sub>16</sub> - 4 <sup>11</sup> / <sub>16</sub>
89600533-89600542	120 - 129	4 <sup>3</sup> / <sub>4</sub> - 5 <sup>1</sup> / <sub>16</sub>
89600543-89600552	130 - 139	5 <sup>1</sup> / <sub>8</sub> - 5 <sup>1</sup> / <sub>2</sub>
89600553	140	5 <sup>1</sup> / <sub>2</sub>

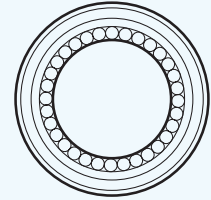
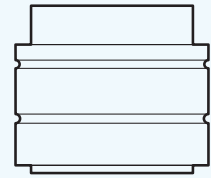

## Lower Self-aligning GRP Tube Bearings

- Manufactured with a GRP tube for easy laminating on installation
- Suit rudder stock diameters 50mm–150mm
- Bearing includes self-aligning ball and precision Delrin rollers
- Accepts sealing system for neoprene gaitor
- No grease or maintenance required

Part Number	Rudder Stock Diameter	
	mm	in
89601077-89601086	50 - 59	1 <sup>15</sup> / <sub>16</sub> - 2 <sup>3</sup> / <sub>16</sub>
89601087-89601096	60 - 69	2 <sup>3</sup> / <sub>8</sub> - 2 <sup>11</sup> / <sub>16</sub>
89601097-89601106	70 - 79	2 <sup>3</sup> / <sub>4</sub> - 3 <sup>1</sup> / <sub>8</sub>
89601107-89601116	80 - 89	3 <sup>1</sup> / <sub>8</sub> - 3 <sup>1</sup> / <sub>2</sub>
89601117-89601126	90 - 99	3 <sup>9</sup> / <sub>16</sub> - 3 <sup>7</sup> / <sub>8</sub>
89601127-89601136	100 - 109	3 <sup>15</sup> / <sub>16</sub> - 4 <sup>5</sup> / <sub>16</sub>
89601137-89601146	110 - 119	4 <sup>5</sup> / <sub>16</sub> - 4 <sup>11</sup> / <sub>16</sub>
89601147-89601156	120 - 129	4 <sup>3</sup> / <sub>4</sub> - 5 <sup>1</sup> / <sub>16</sub>
89601157-89601166	130 - 139	5 <sup>1</sup> / <sub>8</sub> - 5 <sup>1</sup> / <sub>2</sub>
89601167-89601176	140 - 149	5 <sup>1</sup> / <sub>2</sub> - 5 <sup>7</sup> / <sub>8</sub>
89601177	150	6



## Locking Rings

- Used with upper bearings without integral locking ring
- Manufactured in 6082 aluminum and anodized
- Suit rudder stock diameters 50mm–120mm
- Stainless set screws secure locking ring to rudder stock

Part Number	Rudder Stock Diameter	
	mm	in
89600300-89600309	40 - 49	1 <sup>1</sup> / <sub>2</sub> - 1 <sup>15</sup> / <sub>16</sub>
89600310-89600319	50 - 59	1 <sup>15</sup> / <sub>16</sub> - 2 <sup>3</sup> / <sub>16</sub>
89600320-89600329	60 - 69	2 <sup>3</sup> / <sub>8</sub> - 2 <sup>11</sup> / <sub>16</sub>
89600330-89600339	70 - 79	2 <sup>3</sup> / <sub>4</sub> - 3 <sup>1</sup> / <sub>8</sub>
89600340-89600349	80 - 89	3 <sup>1</sup> / <sub>8</sub> - 3 <sup>1</sup> / <sub>2</sub>
89600350-89600359	90 - 99	3 <sup>9</sup> / <sub>16</sub> - 3 <sup>7</sup> / <sub>8</sub>
89600360-89600369	100 - 109	3 <sup>15</sup> / <sub>16</sub> - 4 <sup>5</sup> / <sub>16</sub>

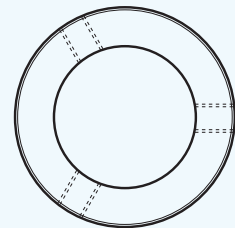

# Rudder Bearings and Stocks (continued)

## Lip Seals

- Used with upper bearings without integral locking ring
- Manufactured in 6082 aluminum and anodized
- Suit rudder stock diameters 50mm–120mm
- Stainless set screws secure locking ring to rudder stock

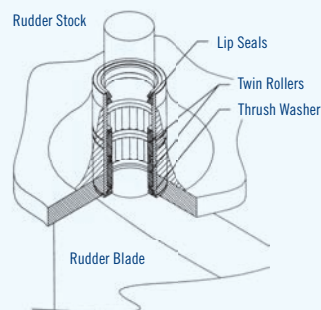

Part Number	Inside Diameter		Outer Diameter	
	mm	in	mm	in
89600230- 89600239	40 - 49	1 1/2 - 1 15/16	65	2 9/16
89600240- 89600249	50 - 59	1 15/16 - 2 3/16	75	2 15/16
89600250- 89600259	60 - 69	2 3/8 - 2 11/16	85	3 3/8
89600260- 89600269	70 - 79	2 3/4 - 3 1/8	95	3 3/4
89600270- 89600279	80 - 89	3 1/8 - 3 1/2	105	4 1/8
89600280- 89600289	90 - 99	3 9/16 - 3 7/8	115	4 1/2
89600290- 89600299	100 - 109	3 15/16 - 4 5/16	125	4 15/16



# Rudder Bearings and Stocks (continued)

## Gaitors

- Manufactured from neoprene
- Supplied with stainless steel hose clamps
- Only use a gaitor a minimum 100mm above static water line level



### Important Note

Gaitors manufactured upon request to suit rudder stock and alloy tube as required.

## Rudder Stocks

Lewmar rudder stocks are produced to specific custom requirements, from either naval architects' designs or via Lewmar's own in-house design capability.

Rudder stocks are manufactured in Aluminum and Stainless Steel – complete with reinforcing tangs to ensure maximum rigidity. Bespoke versions that incorporate aero foils or bar tangs are available to customers' requirements.

**Important Note:** Never earth electrical equipment to a stainless steel or aluminum rudder stock; this will lead to a galvanic reaction and corrosion of the rudder stock.

**Note:** When selecting rudder stock and bearing dimensions, Lewmar recommends considering 'non-standard' sizes, e.g. 78mm instead of 80mm. This is because the standard bar material will not provide sufficient tolerances when used, un-machined in the bearing. The necessary tolerance for the rudder shaft to run in roller bearings is +0.00–0.08mm. To achieve the correct fit with the 80mm bearing, it will be necessary to purchase 85mm bar and machine a substantial amount off – 5mm!

Selecting a 78mm stock and bearing that can be manufactured from 80mm bar will be far more economic.

## Features

### (Rudder Stock)

#### Aluminum stocks in A1MgSi1 (6082) material

- Stiff, saltwater resistant, light and economic
- Perfect for sailing yachts with GRP and aluminum hulls
- Tensile strength 330N/mm<sup>2</sup>
- 2% Proof stress is 280N/mm<sup>2</sup>

#### Aluminum stocks in A1ZnMgCu1,5 (7075) material

- Very stiff, must be anodized, salt-water resistant and light
- Perfect for racing yachts with GRP and aluminum hulls
- Tensile strength 530N/mm<sup>2</sup>
- 2% Proof stress is 480N/mm<sup>2</sup>

#### Stainless steel aisi316 (1.4401) (SS2347) material

- Saltwater resistant and economic
- Perfect for cruising
- Tensile strength is 600N/mm<sup>2</sup>
- 2% Proof stress is 205N/mm<sup>2</sup>

#### Stainless steel aisi329 (1.4460) (SS2324) material

- Very stiff, and saltwater resistant
- Perfect for cruising yachts
- Tensile strength is 750N/mm<sup>2</sup>
- 2% Proof stress is 460N/mm<sup>2</sup>



# Distributor List



## Argentina

### North Sails Sud Argentina

Del Arca 59  
1646 San Fernando, Buenos Aires - Argentina  
**tel:** +54 11 4725 0200  
**fax:** +54 11 4746 7561  
**web:** www.northsailsudamerica.com



## Australia

### Barlow Distributors (Australia) Pty Ltd

177 Phillip Street, Redfern NSW, 2016 Australia  
**tel:** + 61 29 318 2128  
**email:** barlow@hotmail.net.au

### Harrold Marine Wholesale Pty Ltd

Unit 3/19 Success Street, Acacia Ridge, Brisbane, Queensland, 4110 Australia  
**tel:** +61 73 277 6563  
**fax:** +61 73 277 6567  
**email:** hmw@optusnet.com.au

### JPW (Aust) Pty Ltd

Unit 3, 51 Division Street  
Welshpool, Western Australia, 6106 Australia  
**tel:** +61 89 351 9266  
**fax:** +61 89 351 9266  
**email:** ghunter@jpwmarine.com.au



## Austria

### Alltechnik GmbH

Rheinboldtstrasse 11-13  
A 2362 Biedermannsdorf  
Bei Wien, Austria  
**tel:** +43 2236 6467 60  
**fax:** +43 2236 64676 76  
**email:** office@allroundmarin.com  
**web:** www.allroundmarin.com



## Brazil

### Sailing Products

Avenida das Americas, 500 BL 11/207 Downtown  
Barra, CEP 22640-100  
Rio De Janeiro, Brazil  
**tel:** +55 2131549990  
**fax:** +55 2124947223  
**email:** sailing@sailing.com.br  
**web:** www.sailing.com.br



## Bulgaria

### Yacht Shop Bulgaria (Transcommerce)

Passenger Terminal, 2 Floor  
Port Varna, Bulgaria  
**tel:** +359 52 69 22 99  
**email:** info@LYyachting.com  
**web:** www.LZyachting.com



## Canada

### Payne's Marine Group

2120 Quadra Street  
Victoria, BC V8T 4B9, Canada  
**tel:** +250 382 7722  
**fax:** +250 382 4043  
**email:** sales@paynesmarine.com  
**web:** www.paynesmarine.com

## Payne's Marine Group

2360 Industrial Street  
Burlington, Ontario L7P 1A1, Canada  
**tel:** +905 332 8291  
**fax:** +905 332 0557  
**email:** sales@paynesmarine.com  
**web:** www.paynesmarine.com



## Canary Islands

### Rolnautic S.L.

Calla Cuzco No 8, El Cebadal  
Las Pamas De Grand Canarias 35008, Canary Islands  
**tel:** +34 928296811  
**fax:** +34 9282300344  
**email:** jcrodriguez@rolnautic.com



## Chile

### Winncorp LTDA

Tobalaba 1781, Providencia, Santiago, Chile  
**tel:** +011 56 221 26494  
**fax:** +011 56 224 67168



## Croatia

### Maritima d.o.o.

Put Sepurine 1  
22203 Rogoznica, Croatia  
**tel:** +385 (0) 22 558 130  
**fax:** +385 (0) 22 558 131  
**email:** info@nautical-equipment.com  
**web:** www.nautical-equipment.com



## Czech Republic

### Avar Yacht

Areál ZD Veverske Kninice  
664 81 Ostrovacice, Czech Republic  
**tel:** +420 546 428015  
**fax:** +420 546 428075  
**email:** yacht@avaryacht.cz  
**web:** www.avaryacht.cz



## Denmark

### Selden Mast A/S

Bakkegardsvej 406  
DK-3050 Humlebaek, Denmark  
**tel:** +45 39 18 44 00  
**fax:** +45 39 27 17 00  
**email:** info@seldenmast.dk  
**web:** www.seldenmast.dk



## Finland

### Oy Maritim

P.O. Box 46, Veneentekijäntie 1  
Helsinki 210, Finland  
**tel:** +358 (0)207 65180  
**fax:** +358 (0)207 652942  
**email:** maritim@maritim.fi  
**web:** www.maritim.fi



## France

### Accastillage Bernard

880 Avenue St Exuperie, 6210, Mandelieu, France  
**tel:** +33 4 93 90 47 47  
**fax:** +33 4 93 90 47 53  
**email:** contact@accastillage-bernard.fr  
**web:** www.accastillage-bernard.com

### Technique Distribution

Z.A. De Kermaquer, 56470, La Trinité Sur Mer, France  
**tel:** +33 297557256  
**fax:** +33 297557258  
**email:** contact@technique-greement.com



## Germany

### Lankhorst/Hohorst GmbH

Bonifatiusstrasse 411, D 48432 Rheine, Germany  
**tel:** +49 59 719707  
**fax:** +49 59 716064  
**email:** info@lankhorst-hohorst.de  
**web:** www.lankhorst-hohorst.de



## Gibraltar

### M Sheppard & Co Ltd

Waterport Wharf, PO Box 899, Gibraltar  
**tel:** +350 75148  
**fax:** +350 42535  
**email:** admin@sheppard.gi  
**web:** www.sheppard.gi



## Greece

### Nautilus Ltd

Posidonos Av 33/, Metamorfoseos Str 2, Alimos  
Athens 17455, Greece  
**tel:** +30 210 9854238  
**fax:** +30 210 9849 444  
**email:** info@nautilus.gr  
**web:** www.nautilus.gr



## Hong Kong

### Piercey Marine

93 Che Keng Tuk Road, Sai Kung, Hong Kong  
**tel:** +(852) 27914106  
**fax:** +(852) 27914124  
**email:** pmltd@netnavigator.com



## Hungary

### Hullam 04 KFT

8220 Balatonalmadi, Füzfői ut 9, Hungary  
**Tel** +36 88 432 897  
**Fax** +36 88 432 897  
**info@fukeyacht.hu**  
**www.fukeyacht.hu**



## Ireland

### Western Marine

Bulloch Harbour, Dalkey  
Co Dublin, Ireland  
**tel:** +353 01 2800321  
**fax:** +353 01 2800327  
**email:** marine@iol.ie

# Distributor List



## Israel

### Atlantis Marine Ltd

147, Kikar Atarim, 169 Hayarkon Street  
Tel Aviv, 63453, Israel  
**tel:** +972 3 522 7978  
**fax:** +972 3 523 5150  
**email:** atlantis@inter.net.il  
**web:** www.atlantis-marine.co.il



## Italy

### Osculati Spa

via Pacinotti, 12  
20090 Segrate (Milano), Italy  
**tel:** +39 02 2699 111  
**fax:** +39 02 26991120  
**email:** info@osculati.it  
**web:** www.osculati.com



## Japan

### ISCO/Industrial Suppliers Co Ltd SA

NAC Minato Building 2F  
2-1-24 Kaigan, Minato-ku, Tokyo, 105-0022, Japan  
**tel:** +81 3 5443 8231/8234  
**fax:** +81 3 5443 8240/8241  
**email:** sales@isco.co.jp  
**web:** www.isco.co.jp

### Nakamura Sengu Kogyo Co Ltd

6-15 Nagata-Higashi 3 Chome  
Minami-Ku, Yokohama, 232, Japan  
**tel:** +81 4 5713 5481  
**fax:** +81 4 5713 8373  
**email:** nakasen@marinevance.com



## Kuwait

### Seas & Deserts

Amiry Trade Centre, Shuwaikh Bank Street  
PO Box 110, Safat 13002, Kuwait  
**tel:** +965 4 849 212  
**fax:** +965 4 845 346  
**email:** sales@seadesert.com  
**web:** www.seadesert.com



## Malta

### Gauci Borda & Co Ltd

53 Msida Road, Gzira, GZR 03, Malta  
**tel:** +356 21313758  
**fax:** +356 2134 3604  
**email:** info@gauciborda.com  
**web:** www.gauciborda.com



## Martinique

### Caraibes Greement

Boulevard Allegre  
97290 Le Marin, Martinique  
**tel:** +596 74 80 33  
**fax:** +596 74 66 98  
**email:** cgmar@wanadoo.fr



## Netherlands

### Lankhorst Taselaar Bv

Binnenhavenweg 31. 8211 AA  
Lelystad, Netherlands  
**tel:** +31 320 274611  
**fax:** +31 320 231912  
**email:** info@lankhorst-taselaar.nl  
**web:** www.lankhorsttaselaar.nl



## New Zealand

### Kiwi Yachting Consultants Ltd

15 Westmoreland St West, Grey Lynn  
Auckland, New Zealand  
**tel:** +64 (0)9 360 0300  
**fax:** +64 (0)9 360 0302  
**email:** sales@kiwiyachting.co.nz  
**web:** www.kiwiyachting.co.NZ



## Norway

### Leif H Strom A/S

Hasleveien 15, N-0571, Oslo, Norway  
**tel:** +47 23 23 39 70  
**fax:** +47 23 23 39 71  
**email:** mail@stroem.no  
**web:** www.stroem.No



## Poland

### Aura

Ul Przechylna 13, 70-800 Szczecin, Poland  
**tel:** +48 91 4613992  
**fax:** +48 91 4613741  
**email:** michal@aura.szczecin.pl  
**web:** www.aura.szczecin.pl



## Portugal

### Grupo Euronete

Lugar do Rio, Nogueira da Maia  
PO Box 1029, 4471-909 Maia, Portugal  
**tel:** +351 229619200  
**fax:** +351 229605757



## Russia

### 000 Moreman

19, building 2  
Gamalei street Moscow, 123098, Russia  
**tel:** +7 495 1013362  
**fax:** +7 499 1937111  
**email:** info@moreman.ru  
**web:** www.moreman.ru



## Singapore

### Alquest Marketing

66, Tannery Lane, #02-06B Sindo Building  
347805, Singapore  
**tel:** +65 6749 9359  
**fax:** +65 6749 9360  
**email:** jason@alquest.com.sg  
**web:** www.alquest.com.sg



## Slovenia

### Seawave Marine D.O.O

Alpska Cesta 0043, 4248 Lesce, Slovenia  
**tel:** +386 (0)4 5302 444  
**fax:** +386 (0)4 5302 440  
**email:** info@seawave-marine.si  
**web:** www.seawave-marine.si



## South Africa

### Central Boating

85 Bree Street  
Cape Town, 8001, South Africa  
**tel:** +27 21 424 8026  
**fax:** +27 21 424 2564  
**email:** info@centralboating.co.za  
**web:** www.centralboating.co.za



## Spain

### Acastillaje Synera SL

Passeig Joan de Borbós, 92, 08039  
Barcelona, Spain  
**tel:** +34 93 225 49 34  
**fax:** +34 93 225 19 49  
**email:** info@sinerarigging.com  
**web:** www.sinerarigging.com



## Sweden

### Navship AB

Box 37, SE-427 21 Billdal, Sweden  
**tel:** +46 31 93 96 00  
**fax:** +46 31 91 45 56  
**email:** info@navship.se  
**web:** www.navship.se



## Switzerland

### Bucher + Walt SA

Route de Soleure 8, CH 2072 St Blaise, Switzerland  
**tel:** +41 327 559500  
**fax:** +41 327 559530  
**email:** info@bucher-walt.ch  
**web:** www.bucher-walt.ch



## Taiwan

### Marineware

2fl, No.172, Section 1 Ling Mi Road, Pali Shiang 249,  
Taipei County, Taiwan  
**tel:** +886 22618 8342



## Thailand

### Phuketsail

3/2-4 Moo 5, Koh Keaw, Phuket City,  
Phuket, 83200, Thailand  
**tel:** +66 76 377542  
**fax:** +66 76 238494  
**email:** ecommerce@phuleksail.com  
**web:** www.phuketsail.com



# Distributor List



## Turkey

### Kaptan Denizcilik Ticaret A.S.

Ahmet Mithat Efendi Cad 13/1,81030 Kalamis  
Istanbul, Turkey

tel: +90 216 337 2000

fax: +90 216 348 2999

email: info@kaptandenizcilik.com

web: www.kaptandenizcilik.com



## United Arab Emirates

### Delma Industrial Supply & Marine Service

P.O. Box 53382

Abu Dhabi, UAE

tel: +971 2 6668153

fax: +971 2 6668154

email: disms@emirates.net.ae

### Duboats Trading Llc

PO Box 53793

City Tower 2 Sheikh Zayed Road,  
10th Floor, Office 1002

Dubai, UAE

tel: +971 04 332 7771

fax: +971 04 332 2456

email: c.vanek@duboats.com



## United Kingdom

### Bainbridge International Ltd

8 Flanders Park, Hedge End  
Southampton, Hampshire, SO30 2FZ

tel: +44 (0)1489 776000

fax: +44 (0)1489 776048

email: info@bainbridgeint.co.uk

web: www.bainbridgeint.com

## Whitlock South

17 Hollybank Lane,  
Emsworth Hants, PO10 7UD

tel: +44 (0) 1243 430050

email: enquiries@winchservicing.com

web: www.winchservicing.com



## USA

### Lewmar

351 New Whitfield Street, Guilford, CT, 06437, USA

tel: +1 203 458 6200

fax: +1 203 453 5669

email: info@lewmarusa.com

For a complete list US distributors please visit:

<http://www.lewmar.com/usa/distributors.htm>



## Venezuela

### Intermarine

AV Intecomunal De Guatire

Cruse Con C, La Arenera, Venezuela

tel: +58 0212 344 16 77

fax: +58 0212 344 14 23

web: www.intermarine.com.ve

## Caribbean

### Antigua Rigging

Falmouth Harbor, Antigua

tel: +268 562 1294

fax: +268 463 8575

email: info@antiguarigging.com

web: www.antiguarigging.com

## Budget Marine

Western Main Road, Chaguaramas, Trinidad

tel: +1 904-477-8011

email: sales@budmar.an

web: www.budmar.an

## Caraibes Greement

2 Porte de la Marina, 97110 Pointe A Pitre

Guadeloupe, Guadeloupe

tel: +590 908201

fax: +590 909750

email: caraibe.greement@wanadoo.fr

## FKG Marine Rigging & Fabrication NV

Postal Address: PO Box 5011, Philipsburg, St Maarten

Physical Address: 37 Wellington Road, Cole Bay,

St. Maarten, Netherlands Antille

tel: +599 544 4733

mobile: +599 557 8502

fax: +599 544 2171

email: info@fkg-marine-rigging.com

web: www.fkg-marine-rigging.com

## Island Rigging and Hydraulics

8186 Sub Base Road, Suite 4

St. Thomas, USVI, 00802

tel: 011-340-774-6833

fax: 011-340-774-5024

email: islrig@viaccess.net

## Martinez Marine Service

Puerto del Rey Marina Suite #103

Highway #3, Km 51.4

Fajardo, PR, 00738

tel: (787) 863-4646

fax: (787) 272-8172

web: www.martinezmachine.com



# Part Number List

0034021210	18	19701600	99	29145302	76	29315369	155	29432312	166	29471027	172	29901412	139
0034021212	18	19810600	135	29145311	76	29316139	155	29432315	166	29471030	171	29901420	139
0034021214	18	19811000	158	29145312	76	29316339	155	29432316	166	29471031	171	29901421	138
0034022210	18	19820600	135	29160112	165	29316369	155	29432372	166	29471032	171	29901421	139
0034022212	18	19821000	158	29160310	162	29316749	155	29432400	166	29471035	171	29901422	138
0034022214	18	19830500	135	29160315	162	29317139	155	29432411	168	29471036	171	29901422	139
0036022212	18	19850500	135	29160410	163	29317659	155	29432411	166	29471037	171	29901423	139
0036022214	18	19861100	156	29160415	163	29317849	155	29432412	166	29471041	172	29901424	139
0036022216	18	19899000	70	29160420	163	29318139	155	29432415	166	29471042	172	29901425	139
0052505	91	19899100	70	29161110	162	29319139	155	29432416	168	29471063	172	29901426	138
0052505	25	19899200	70	29161115	162	29319949	155	29432416	166	29471063	172	29901426	139
0052505	91	19899300	70	29161120	162	29324033	154	29432420	168	29471836	171	29901428	139
0052506	25	19899400	70	29161130	162	29330105	164	29432424	167	29472010	172	29901429	139
0052509	25	19899500	70	29161310	162	29330170	164	29432426	167	29472012	172	29901430	139
0052519	25	19899600	70	29161315	162	29333245	164	29432500	168	29472015	172	29901441	138
0052529	25	28003225	172	29161320	162	29333246	174	29432500	167	29472018	172	29901441	139
0052530	25	28003226	172	29161410	163	29333247	174	29432511	168	29472020	172	29901447	138
0052531	25	28003642	150	29161415	163	29333248	174	29432512	168	29472027	172	29901447	139
0056205	29	29020701	164	29161420	163	29333250	174	29432814	168	29472030	171	29901448	139
0056206	29	29030100	164	29161430	163	29333269	174	29432814	167	29472031	171	29901449	139
0056207	29	29030600	164	29161510	162	29334134	181	29432816	167	29472032	171	29901460	138
0056208	29	29034509	181	29161515	162	29347029	181	29432822	168	29472035	171	29901463	139
0056209	29	29034709	181	29161520	162	29347030	181	29432822	167	29472036	171	29901600	142
0056210	29	29040100	164	29162110	162	29383119	154	29432823	168	29472037	171	29901611	142
0056211	29	29040600	164	29162115	162	29384139	156	29432823	167	29472038	172	29901612	142
0056503	29	29041700	177	29162120	162	29384169	156	29432832	167	29472041	172	29901613	142
0056504	29	29042700	177	29162130	162	29385139	156	29432833	168	29472042	172	29901614	142
0056505	29	29042704	177	2916 2310	162	29385169	156	29432833	167	29472062	172	29901615	142
0056506	29	29043702	177	29162315	162	29386139	156	29432836	167	29472063	172	29901624	143
0056507	29	29044829	181	29162320	162	29386149	156	29432838	168	29472064	172	29901631	143
0056508	29	29044869	181	29162410	163	29386169	156	29432838	167	29472076	171	29901634	143
0056509	29	29060152	165	29162415	163	29387139	156	29432916	167	29472501	171	29901639	143
0056510	29	29101108	124	29162420	163	29387169	156	29433300	175	29472535	171	29901647	143
0056511	29	29101110	124	29162430	163	29388139	156	29433300	174	29472601	173	29901651	140
0056513	29	29101112	124	29162510	162	29388169	156	29433314	175	29472616	171	29901652	140
0056515	29	29101208	124	29162515	162	29389139	156	29433314	174	29472836	171	29901653	140
0056530	29	29101210	124	29162610	163	29389169	156	29433383	175	29472970	154	29901654	140
0056540	29	29101212	124	29162620	163	29390013	156	29433400	174	29473024	176	29901655	140
0056550	29	29101308	125	29162630	163	29390014	156	29433414	175	29473030	176	29901656	140
0056560	29	29101310	125	29163310	162	29393000	158	29433414	174	29473032	176	29901659	140
0056570	28	29101312	125	29163320	162	29394016	156	29433416	175	29473035	176	29901660	140
0057306	28	29101410	125	29163325	162	29394052	156	29433416	175	29473036	176	29901661	140
0057310	28	29101412	125	29163330	162	29394054	156	29433602	174	29473037	176	29901665	140
0057316	28	29101414	125	29163610	163	29396019	156	29433602	174	29473037C	176	29901667	140
0057320	28	29101501	125	29163615	163	29396050	156	29433682	174	29473040	176	29901668	140
0057325	28	29102410	125	29163620	163	29396051	156	29433683	174	29473041	176	29901670	140
0057332	28	29102412	125	29163630	163	29396052	156	29433832	174	29473063	176	29901677	140
0057340	28	29102414	125	29166215	163	29396053	156	29433833	174	29473135	176	29901807	144
0057350	28	29103410	125	29166225	163	29396054	156	29441301	170	29473136	176	29901811	144
0057363	28	29103412	125	29166230	163	29396055	156	29441311	170	29483037C	176	29901812	144
0057404	28	29103414	125	29170022	178	29396056	156	29441311	170	29900010	178	29901813	144
0057406	28	29104100	128	29170026	178	29397013	156	29441312	170	29900011	178	29901814	144
0057410	28	29104100	128	29170030	164	29399013	156	29441322	170	29900012	178	29901815	144
0057416	28	29104101	128	29170033	164	29399052	156	29441331	170	29900013	178	29901816	144
0057420	28	29104103	128	29170040	164	29399054	156	29441332	170	29900014	178	29901821	146
0057425	28	29104104	128	29170040	165	29421300	167	29441332	170	29900015	178	29901822	145
0057432	28	29104110	128	29170041	164	29421366	170	29441345	170	29900016	178	29901824	145
0057440	28	29104113	128	29170046	178	29421400	167	29441500	170	29900017	178	29901825	146
0057450	28	29104114	128	29170046	178	29421400	166	29441513	170	29900240	138	29901825	146
0057450	28	29104114	128	29171010	165	29422300	167	29441701	171	29900240	138	29901828	146
0057463	28	29104115	128	29171020	178	29422300	166	29441720	170	29901107	147	29901829	146
0057901	30	29104116	128	29171021	178	29422400	167	29441723	170	29901137	147	29901830	146
0057902	30	29111000	159	29171022	178	29422400	166	29441730	170	29901157	147	29901831	145
0057905	30	29113000	159	29171026	178	29423301	175	29442301	170	29901170	148	29901831	145
0057907	30	29139102	126	29171040	172	29423301	174	29442311	170	29901171	148	29901834	145
0057910	30	29139103	126	29171046	178	29423302	174	29442312	170	29901174	148	29901839	145
0057915	30	29139104	126	29172015	177	29423400	174	29442321	170	29901201	148	29902024	138
0057920	30	29139105	126	29172016	177	29423900	174	29442322	170	29901204	148	29902034	138
0057930	30	29139106	126	29172020	178	29431300	166	29442331	170	29901221	148	29902035	138
0057950	30	29139112	126	29172021	178	29431300	166	29442332	170	29901224	148	29902061	154
0057980	178	29139113	126	29172026	178	29431311	167	29442345	170	29901251	148	29902100	152
0058901	30	29139114	126	29172027	154	29431311	166	29442412	168	29901254	148	29902101	152
0058902	30	29139115	126	29172040	172	29431312	167	29442500	170	29901301	138	29902108	153
0058905	30	29139116	126	29172044	178	29431312	166	29442700	170	29901311	138	29902109	153
0058907	30	29140001	76	29172046	178	29431315	166	29442701	170	29901314	139	29902131	152
0058910	30	29140002	76	29172117	177	29431316	166	29442705	177	29901314	138	29902138	153
0058915	30	29140003	76	29173020	178	29431337	168	29442720	177	29901320	138	29902139	153
0058920	30	29140005	76	29173021	178	29431337	166	29442730	177	29901321	138	29902151	152
0058930	30	29140011	75	29173026	178	29431400	167	29442730	177	29901322	138	29902158	153
18000200	25	29140012	75	29173027	154	29431400	166	29443310	175	29901323	139	29902159	153
18000237	25	29140013	75	29173040	176	29431411	168	29443310	175	29901323	138	29902178	153
18000254	21	29140015	75	29173044	178	29431411	166	29443311	175	29901324	139	29902179	

29904042	143	29921059	133	29946131	151	39670070	52	48077209	87	49058000	85	589006	38
29904043	140	29924061	134	29946132	151	39677050	52	89300053	223	49058001	85	589006	40
29904043	143	29924062	134	29946611	151	39677070	52	49006010	81	49058002	85	589007	40
29904046	138	29925001	131	29946612	151	39900030	48	19006100	81	49058003	85	589008	40
29904046	139	29925002	131	29946801	151	39903030	48	19006190	81	49058004	85	589008	92
29904046	158	29925003	131	29946802	151	39910030	48	49007030	81	49058019	85	589009	40
29904050	158	29925004	131	30067300	48	399100303	48	49007031	81	49058040	109	589009	92
29904053	158	29925004	131	30069900	55	39918030	48	49007032	81	49058100	97	589010	40
29904054	158	29925005	131	30074000	55	39922030	48	49008030	81	49058101	97	589011	40
29904060	158	29925009	131	30133000	64	39930020	50	49008031	81	49058104	97	589012	40
29904100	128	29925010	131	30157900	58	39930030	48	49008032	81	49058103	97	589013	38
29904101	128	29925021	133	30158000	58	399300303	48	49014000	82	49058102	97	589013	40
29904104	128	29925021	131	30158100	58	39940020	50	49014001	82	49058200	86	589015	40
29904105	128	29925031	131	30158200	58	39940030	48	49016000	82	49058201	86	589016	40
29904111	128	29925034	131	30158300	59	399400303	48	49016001	82	49060000	107	589017	40
29904114	128	29925037	131	30158400	59	39941030	48	49016019	82	49060009	107	589018	40
29904115	128	29925039	131	30158500	59	39944020	50	49016002	82	49060014	109	589019	40
29904117	128	29925040	159	30160000	55	39944030	48	49016003	82	49062040	109	589020	40
29904118	128	29925050	159	30162600	58	399440303	48	49016030	81	49065000	85	589021	40
29904118	128	29926001	131	30162700	58	39950020	50	49016031	81	49065001	85	589025	40
29904126	128	29926002	131	30162800	58	39950030	48	49016032	81	49065002	85	589029	41
29905105	172	29926003	131	30162900	58	399500303	48	49030000	82	49065003	85	589030	41
29905200	172	29926004	131	30163000	59	39951030	48	49030001	82	49065004	85	589031	41
29905400	179	29926005	131	30163100	59	39954020	50	49030002	82	49065019	85	589034	41
29905401	179	29926010	131	30163200	59	39954030	48	49030003	82	49065100	97	589035	41
29905410	128	29926021	133	360259990	60	399540303	48	49030019	82	49065101	97	589064	41
29905412	179	29926021	131	360918999	60	39960020	50	49030030	81	49065102	97	589065	41
29905412	128	29926029	131	361041990	60	39960030	48	49040030	81	49065103	97	589066	41
29905414	179	29926031	131	361042992	60	399600303	48	49040040	109	49065104	97	589069	40
29906171	151	29926034	131	361196992	60	39965030	48	49040055	82	49065200	86	589070	40
29906172	151	29926037	131	361196995	60	39970020	50	49040056	82	49065201	86	589071	40
29906251	151	29926039	131	367110916	70	39977020	50	49040057	82	49066000	85	589072	40
29906252	151	29926040	159	367110936	70	40000899	109	49040058	82	49066001	85	589073	40
29906452	127	29926050	159	367130916	70	40000900	109	49040059	82	49066002	85	589074	40
29906453	127	29926061	134	367130936	70	40000901	109	49040060	82	49066003	85	589075	40
29906453	127	29926064	134	367132916	70	40002729	109	49040061	86	49066004	85	589076	40
29906454	127	29927201	132	367132936	70	40002731	109	49040062	86	49066005	85	589101	40
29906455	127	29927202	132	367140916	70	40002741	109	49044005	81	49066006	85	589102	40
29906456	127	29927203	132	367140936	70	40004751	109	49044007	81	49066008	85	589103	40
29906457	127	29927204	132	367160916	70	40004751	85	49044008	81	49066009	85	589110	41
29906458	127	29927205	132	367160936	70	40005066	107	49044014	109	49066019	85	589150	41
29906601	150	29927210	132	367302916	70	45005199	92	49044019	83	49068001	107	589151	41
29906602	150	29927221	133	367302936	70	48000022	89	49044040	109	49068002	107	589300	40
29906604	150	29927221	132	367302966	70	48000023	89	49046055	83	49068021	107	589301	40
29906605	150	29927231	132	367312916	70	48000075	89	49046056	83	49068100	97	589302	40
29906606	150	29927234	132	367312936	70	48000076	89	49046057	83	49068101	97	589303	40
29906607	150	29927237	132	367312966	70	48000077	89	49046058	83	49068102	97	589310	41
29906621	150	29927239	132	367318916	70	48000078	89	49046059	83	49068103	97	589320	41
29906622	150	29927240	159	367318936	70	48000081	91	49046060	83	49068104	97	589321	41
29906652	127	29927250	159	367318966	70	48000082	91	49046155	95	49068105	97	589350	41
29906653	127	29927261	134	367322916	70	48000083	91	49046156	95	49068106	97	589351	41
29906654	127	29927264	134	367322936	70	48000084	91	49046158	95	49068108	97	589501	40
29906654	127	29929001	132	367332916	70	48000085	91	49046159	95	49068109	97	589502	40
29906655	127	29929002	132	367332936	70	48000086	91	49046160	95	49077000	85	589503	40
29906656	127	29929002	132	367342916	70	48000087	91	490462551	86	49077001	85	589510	41
29906811	150	29929003	132	367342936	70	48000088	91	490462561	86	49077003	85	589550	41
29906812	150	29929004	132	367344936	70	48000089	91	49048014	109	49077004	85	589551	41
29906814	150	29929021	133	367346936	70	48000090	91	49048040	109	49077005	85	589552	41
29906815	150	29929031	132	367352916	70	48000091	91	49048055	83	49077006	85	589700	40
29906816	150	29929034	132	367352936	70	48000092	91	49048056	83	49077008	85	589701	40
29906817	150	29929034	132	367378916	70	48000093	91	49048057	83	49077009	85	589702	40
29906821	150	29929039	132	367378936	70	48000094	91	49048058	83	49077035	109	589703	40
29906822	150	29929040	159	367378966	70	48000116	89	49048059	83	49077100	97	589710	41
29911089	157	29929050	159	367382966	70	48000117	89	49048060	83	49077101	97	589750	41
29911091	157	29929061	134	39110090	68	48000170	92	49048155	95	49077103	97	589751	41
29911091	157	29929064	134	39110070	68	48000170	25	49048156	95	49077104	97	591401	37
29911098	157	29941100	147	39130090	68	48040055	93	49048158	95	49077105	97	591402	37
29911120	157	29941101	147	39130070	68	48040255	87	49048159	95	49077106	97	591801	37
29911121	157	29941102	147	39132090	68	48046055	93	49048160	95	49077108	97	591802	37
29911123	157	29941104	147	39132070	68	48046255	87	490482551	86	49077109	97	591803	37
29911131	157	29941130	147	39140090	68	48048055	93	490482561	86	49082000	107	591804	37
29912056	154	29941131	147	39140070	68	48048255	87	49050000	83	49088004	85	591805	37
29912057	154	29941134	147	39160090	68	48050055	93	49050001	83	49088009	85	591806	37
29912058	154	29941150	147	39160070	68	48050200	87	49050002	83	49088104	97	591807	37
29912059	154	29941151	147	393020262	64	48050203	87	49050003	83	49088109	97	591808	37
29912060	154	29941154	147	393010262	64	48054055	93	49050004	83	49088214	86	591833	37
29912074	154	29941600	142	393120262	64	48054200	87	49050014	109	49095001	107	591834	37
29912084	154	29941611	142	393110262	64	48058055	93	49050019	83	49095004	107	591836	37
29912088	157	29941612	142	393170262	64	48058200	87	49050040	109	49099000	107	592501	37
29912092	154	29941613	142	393180262	64	48065055	87	49050100	95	49099009	107	592502	37
29912095	154	29941614	142	39333268	174	48065200	87	49050101	95	49105002	107	592503	37
29912097	154	29941615	142	39333281	64	48065201	87	49050102	95	49105006	107	593001	37
29912104	154	29941800	144	393770262	64	48065204	87	49050103	95	49111004	85	593002	37
29912108	154	29941801	144	393810862	64	48065203	87	49050104	95	49111009	85	593003	37
29912110	154	29941802	144	39610050	52	480							

6656411197-102	9	66910088-143	17	68000593	25	89100078	205	89400034	194	89600383	231	89700298	186
6656411198-102	9	66910089-143	17	68000595	25	89100079	205	89400035	194	89600384	231	89700299	186
6656811196-303	5	66910090-144	17	68000596	25	89100080	205	89400036	194	89600385	231	89700300	186
6656811197-303	5	66910091-144	17	68000599	25	89100090	205	89400045	195	89600386	231	89700301	186
6657011108-102	7	66910092-144	17	68000602	25	89100091	205	89400046	195	89600387	231	89700302	186
6657011196-102	7	66910093-144	17	68000603	25	89100092	205	89400047	195	89600388	231	89700308	186
6657011197-102	7	66910094-146	17	68000604	25	89100093	205	89400048	193	89600389	231	89700309	186
6657011198-102	7	66910095-146	17	68000627	25	89100094	205	89400084	194	89600453-89600462	232	89700310	186
6670011107	13	66910100-146	17	68000628	25	89100095	205	89400100	196	89600463-89600472	232	89700311	186
6670011196	13	66910101-146	17	68000840	15	89100096	205	89400109	193	89600473-89600482	232	89700312	186
6670011197	13	66910106-146	17	68000844	25	89100098	207	89400109	194	89600483-89600492	232	89700313	186
6671011107-138	15	66910107-146	17	68000845	25	89100099	207	89400117	198	89600493-89600502	232	89700344	188
6671011108-138	15	66910108-146	17	68000845	25	89100100	207	89400118	193	89600503-89600512	232	89700345	188
6671011196-138	15	66910109-146	17	68000847	27	89100111	209	89400120	194	89600513-89600522	232	89700346	188
6671011197-138	15	66910200	23	68000846	27	89100112	209	89400122	194	89600523-89600532	232	89700347	188
6671011198-138	15	66910201	23	69000331	31	89100113	209	89400123	194	89600533-89600542	232	89700348	188
6671011698-138	15	66910202	23	69000332	31	89100114	209	89400125	194	89600543-89600552	232	89700354	188
6671011697-138	15	66910203	23	69000333	31	89100115	209	89400133	193	89600553	232	89700355	188
6671011698-138	15	68000015	20	69000334	31	89100116	205	89400136	193	89601000	230	89700356	188
6672011108-138	15	68000016	20	69000335	31	8910143	185	89400137	193	89601001	230	89700357	188
6672012108-138	15	68000017	21	69000336	31	89100143	186	89400146	193	89601002	230	89700358	188
6672011110-138	15	68000017	20	69000337	31	89100144	186	89400192	198	89601003	230	89700375	185
6672021110-138	15	68000023	19	69000338	31	89100144	187	89400196	193	89601004	230	89700376	185
6672011196-138	15	68000024	19	69000339	31	89100160	223	89400200	197	89601005	230	89700377	185
6672021196-138	15	68000027	21	69000340	31	89100196	208	89400203	197	89601006-89601015	231	89700383	187
6672011197-138	15	68000037	19	69000341	31	89100401	205	89400204	197	89601016-89601025	231	89700406	185
6672021197-138	15	68000043	21	69000342	31	89100403	205	89400205	197	89601026-89601035	231	89700407	185
6672011198-138	15	68000049	20	69000343	31	89100405	205	89400206	197	89601036-89601045	231	89700408	185
6672021198-138	15	68000094	22	69000344	31	89100407	205	89400218	196	89601046-89601055	231	89700410	187
6672012108-140	15	68000099	21	69000345	92	89100409	205	89400222	197	89601077-89601086	232	89700411	187
6672022108-140	15	68000099	22	69000346	92	89100411	205	89400223	197	89601087-89601096	232	89700412	187
6672012110-140	15	68000112	22	69000346	95	89100413	205	89400224	197	89601097-89601106	232	89700413	187
6672022110-140	15	68000113	22	69000350	92	89100415	205	89400274	197	89601107-89601116	232	89700414	187
6672012196-140	15	68000114	21	69000353	10	89100569	208	89400283	198	89601117-89601126	232	89700415	187
6672022196-140	15	68000115	21	69600533	10	89100750	206	89400284	198	89601127-89601136	232	89700416	187
6672012197-140	15	68000116	22	69600534	10	89200032	220	89400285	198	89601137-89601146	232	89700417	187
6672022197-140	15	68000117	22	69600535	10	89200034	219	89400286	198	89601147-89601156	232	89700431	186
6672012198-140	15	68000123	22	69600536	10	89200035	219	89400291	199	89601157-89601166	232	89700432	186
6672022198-140	15	68000129	25	69600537	10	89200037	220	89400298	194	89601167-89601176	232	89700451	187
6672211108-139	15	68000130	25	69600538	10	89200040	219	89400299	194	89601177	232	89700520	185
6672221108-139	15	68000164	22	69600539	10	89200041	220	89400300	194	89700011	186	89700521	185
6672211110-139	15	68000173	21	69600540	10	89200046	220	89400327	188	89700012	186	89700571	187
6672221110-139	15	68000173	22	69600541	10	89200048	221	89400328	197	89700024	186	89700581	187
6672211196-139	15	68000174	21	69600542	10	89200048	220	89400329	196	89700025	186	89700591	187
6672221196-139	15	68000174	22	69600543	10	89200050	221	89400330	196	89700037	186	89700601	187
6672211197-139	15	68000211	22	69600544	10	89200050	220	89400355	196	89700038	186	89700602	187
6672221197-139	15	68000217	22	69600545	10	89200052	221	89400356	196	89700050	186	89700603	187
6672211198-139	15	68000239	92	69600546	10	89200057	217	89400361	195	89700051	186	89700604	187
6672221198-139	15	68000240	25	69600547	10	89201637	195	89400362	195	89700063	186	89700605	187
6672212108-142	15	68000278	22	69600548	10	89300000	227	89400363	195	89700064	186	89700607	187
6672222108-142	15	68000294	24	69600556	23	89300002	227	89400365	198	89700076	186	89700646	186
6672212110-142	15	68000294	17	69600557	23	89300003	223	89400371	197	89700077	186	89800108	187
6672222110-142	15	68000295	22	69000597	25	89300004	227	89400372	197	89700078	186	89900010	190
6672212196-142	15	68000296	22	68000598	25	89300008	227	89400409	198	89700079	186	89900011	190
6672222196-142	15	68000318	25	82000356	214	89300010	227	89400410	198	89700080	186	89900012	190
6672212197-142	15	68000319	25	82000357	214	89300016	225	89500002	214	89700081	186	89900013	193
6672222197-142	15	68000320	25	823GPST	106	89300017	225	89500008	214	89700082	186	89900014	191
6672212198-142	15	68000321	25	89000004	214	89300029	225	89500011	214	89700083	186	89900015	191
6672222198-142	15	68000325	22	89100000	204	89300039	223	89500012	214	89700084	186	89900016	191
66810011	23	68000326	22	89100001	204	89300039	226	89500013	214	89700085	186	89900098	187
66810011	16	68000348	25	89100002	204	89300040	223	89500014	214	89700086	186	89900022	191
66810012	23	68000349	92	89100003	204	89300041	226	89500497	223	89700087	186	89900023	191
66810012	16	68000349	25	89100004	204	89300045	226	89600040-89600049	231	89700088	186	89900024	191
66810024	16	68000350	92	89100006	204	89300049	226	89600050-89600059	231	89700089	186	89900033	190
66810025	16	68000350	25	89100008	204	89300051	223	89600060-89600069	231	89700090	186	89900034	191
66810031	17	68000351	92	89100010	204	89300053	223	89600070-89600079	231	89700091	186	89900037	191
66810032	23	68000351	25	89100015	206	89300053	225	89600080-89600089	231	89700092	186	89900043	191
66830008	26	68000356	17	89100016	206	89300054	225	89600090-89600099	231	89700093	186	89900050	190
66830008	25	68000357	17	89100018	206	89300054	203	89600100-89600109	231	89700094	186	89900052	191
66830008	25	68000358	17	89100019	206	89300055	225	89600110-89600119	230	89700095	186	89900056	191
66830010	26	68000359	17	89100022	206	89300057	223	89600120-89600129	230	89700096	186	89900057	191
66830010	25	68000360	15	89100023	206	89300060	225	89600130-89600139	230	89700097	186	89900198	192
66840003	17	68000361	15	89100024	206	89300060	21	89600140-89600149	230	89700098	186	89900199	192
66840005	17	68000362	15	89100025	206	89300060	223	89600150-89600159	230	89700125	188	89900200	192
66840007	32	68000363	15	89100026	206	89300061	225	89600160-89600169	230	89700126	188	89900202	192
66840008	32	68000368	22	89100027	206	89300064	227	89600160-89600169	230	89700137	188	89900203	192
66840009	32	68000425	22	89100029	206	89300070	158	89600166-89600175	231	89700138	188	89900204	192
66840010	32	68000463	21	89100029	206	89300099	223	89600170-89600179					

# Limited Warranty and Key Terms of Supply by Lewmar

Lewmar warrants that in normal private pleasure boat usage and with proper maintenance its products will conform with their specification for a period of three years from the date of purchase by the end user, subject to the conditions, limitations and exceptions listed below. Any product, which proves to be defective in normal usage during that three-year period, will be repaired or, at Lewmar's option, replaced by Lewmar.

## A CONDITIONS AND LIMITATIONS

- i Lewmar's liability shall be limited to the repair or replacement of any parts of the product which are defective in materials or workmanship.
- ii Responsibility for the selection of products appropriate for the use intended by the Buyer shall rest solely with the Buyer and Lewmar accepts no responsibility for any such selection.
- iii Lewmar shall not be liable in any way for Product failure, or any resulting loss or damage that arises from:
  - a. use of a product in an application for which it was not designed or intended;
  - b. corrosion, ultra violet degradation or wear and tear;
  - c. a failure to service or maintain the product in accordance with Lewmar's recommendations;
  - d. faulty or deficient installation of the product (unless conducted by Lewmar);
  - e. any modification or alteration of the product;
  - f. conditions that exceed the product's performance specifications or safe working loads.
  - g. Abuse
- iv Product subject to a warranty claim must be returned to the Lewmar outlet that supplied the product for examination unless otherwise approved by Lewmar in writing.
- v This warranty does not cover any incidental costs incurred for the investigation, removal, carriage, transport or installation of product.
- vi Service by anyone other than authorized Lewmar representatives shall void this warranty unless it accords with Lewmar guidelines and standards of workmanship.

vii Lewmar's products are intended for use only in the marine environment. Buyers intending to use them for any other purpose should seek independent professional advice as to their suitability. Lewmar accepts no liability arising from such other use.

## B EXCEPTIONS

Cover under this Warranty is limited to a period of one year from the date of purchase by the end user in the case of any of the following products or parts of products:

- Electric motors and associated electrical equipment
- Electronic controls
- Hydraulic pumps, valves and actuators
- Hatch & Portlight weather seals
- Products used in "Grand Prix" racing applications
- Products used in commercial or charter applications
- Anchor rodes

## C LIABILITY

- i Lewmar's liability under this warranty shall be to the exclusion of all other warranties or liabilities (to the extent permitted by law). In particular (but without limitation):
  - a. Lewmar shall not be liable for:
    - Any loss of anticipated turnover or profit or indirect, consequential or economic loss;
    - Damages, costs or expenses payable to any third party;
    - Any damage to yachts or equipment;
    - Death or personal Injury (unless caused by Lewmar's negligence).

Some states and countries do not allow the exclusion or limitation of incidental or consequential damages, so the above limitation or exclusion may not apply to you.

- b. Lewmar grants no other warranties regarding the fitness for purpose, use, nature or satisfactory quality of the products.
- ii Where applicable law does not permit a statutory or implied warranty to be excluded, then such warranty, if permitted by that state or country's law, shall be limited to a period of one year from

the date of purchase by the end user. Some states and countries do not allow limitations on how long an implied warranty lasts, so this limitation may not apply to you.

## D PROCEDURE

Notice of a claim for service under this warranty shall be made promptly and in writing by the end user to the Lewmar outlet that supplied the product or to Lewmar Limited at Southmoor Lane, Havant, Hampshire PO9 1JJ, England.

## E SEVERANCE CLAUSE

If any clause of this warranty is held by any court or other competent authority to be invalid or unenforceable in whole or in part, the validity of the remaining clauses of this warranty and the remainder of the clause in question shall not be affected.

## F OTHER RIGHTS

This warranty gives you specific legal rights, and you may also have other legal rights, which vary from state to state and country to country.

In the case of European States a Consumer customer (as defined nationally) has legal rights under the applicable national law governing the sale of Consumer Goods; this Warranty does not affect those rights.

## G LAW

This warranty shall be governed by and read in accordance with the laws of England or the state or country in which the first end user is domiciled at the time of purchase of the product.

## H DISPUTES

Any dispute arising under this warranty may, at the option of the end-user, be referred to alternative dispute resolution under the rules of the British Marine Federation or to the Courts of the State whose law shall govern the warranty or to the Courts of England and Wales.

The British Marine Federation may be contacted at Marine House, Thorpe Lea Road, Egham, England, TW20 8BF

## UK & International Distribution

Lewmar  
Southmoor Lane  
Havant  
Hampshire  
PO9 1JJ  
England

**Tel:** +44 (0)23 9247 1841  
**Fax:** +44 (0)23 9248 5720  
**Email:** [info@lewmar.com](mailto:info@lewmar.com)

## USA

Lewmar  
351 New Whitfield Street  
Guilford, CT  
06437  
USA

**Tel:** +1 203 458 6200  
**Fax:** +1 203 453 5669  
**Email:** [info@lewmar.com](mailto:info@lewmar.com)

## Northern Europe

Lewmar  
Popovstraat 12  
8013 RK  
Zwolle  
Netherlands

**Tel:** +31 (0)38 427 34 90  
**Fax:** +31 (0)38 421 56 42  
**Email:** [info@holland.lewmar.com](mailto:info@holland.lewmar.com)

## Southern Europe

Lewmar  
18 rue Leonard de Vinci  
Z.A.C. Belle Aire Nord  
17440 AYTRE  
France

**Tel:** +33 5 46 50 50 46  
**Fax:** +33 5 46 50 59 04  
**Email:** [info@lewmar.com](mailto:info@lewmar.com)

## Australia/Asia

Lewmar Navtec Australasia Pty. Ltd.  
6/224 Headland Rd.  
Dee Why  
New South Wales  
2099  
Australia

**Tel:** +61 (2) 9936 7111  
**Fax:** +61 (2) 9936 7112  
**Email:** [info@lewmar.com.au](mailto:info@lewmar.com.au)

**LEWMAR®**

[www.lewmar.com](http://www.lewmar.com)

© Copyright 2007 Lewmar Ltd. All rights reserved.



B10402